

## **Appendix C:**

### **Brackets**

On many houses, brackets abound on the eaves, above the windows and doorways, and they group in clusters around the bay windows of the houses built during Queen Victoria's reign. Of no structural value, brackets soften the otherwise hard horizontal line of the eaves and add a decorative touch. However, they were not used on all houses found in the Heritage Conservation Areas of St. John's. Some brackets are made of a lamination of three thicknesses of pine board, the two outside pieces having a fretted design. Retaining the size and shape of the original brackets is easy to do, and an existing bracket can be used as a template for making a new bracket.

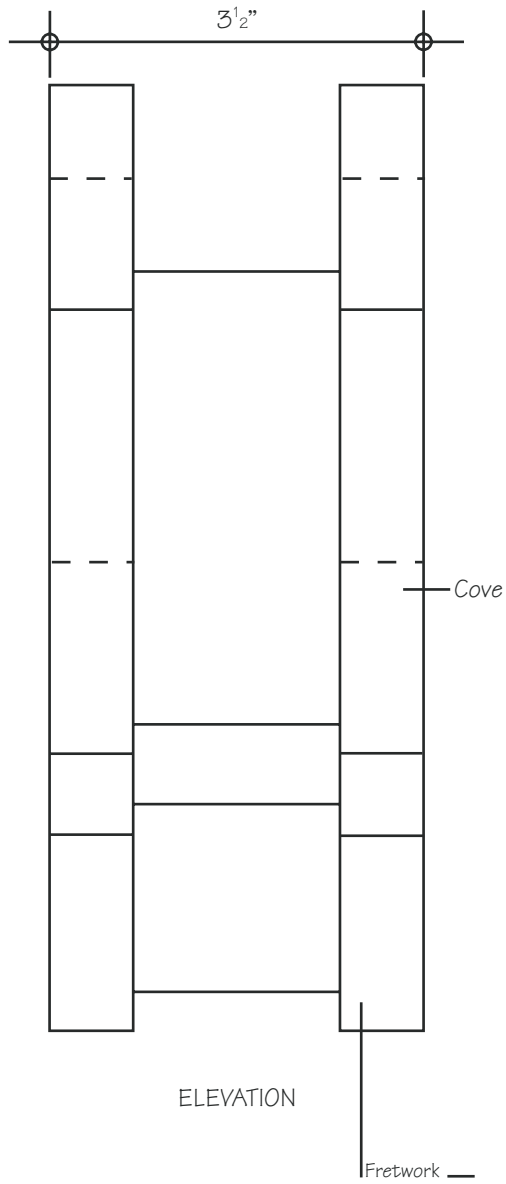



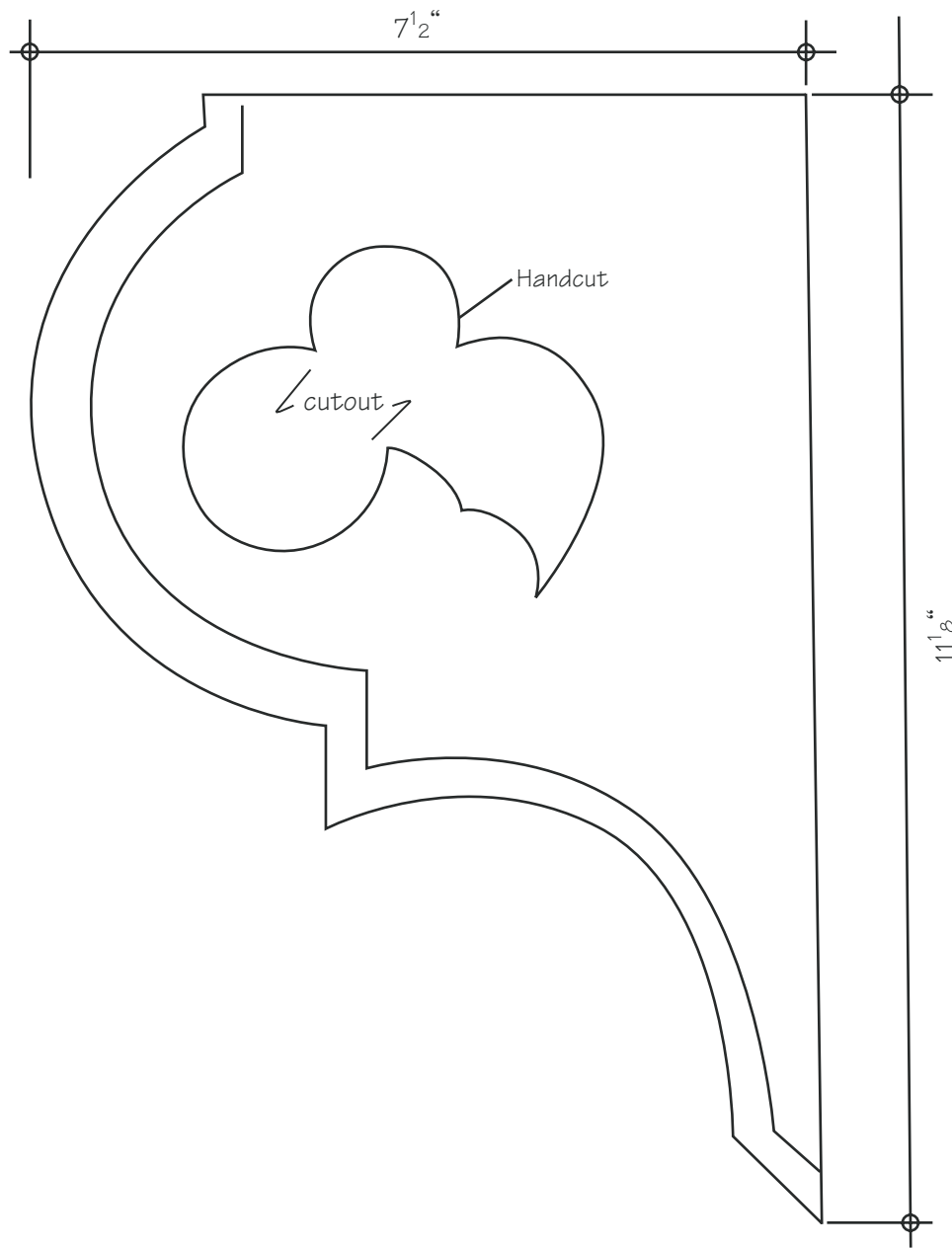

PROFILE

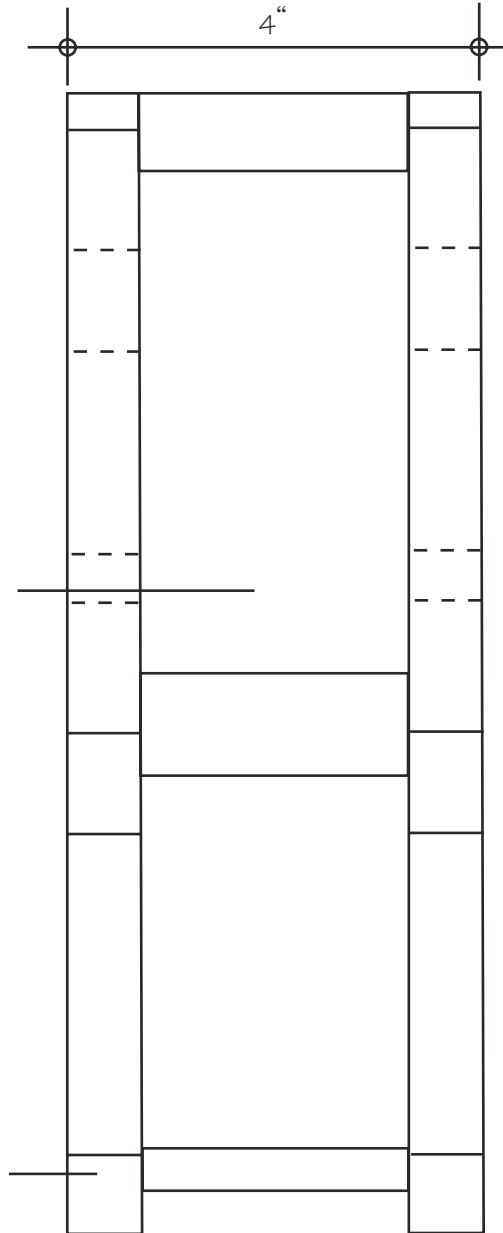

ELEVATION

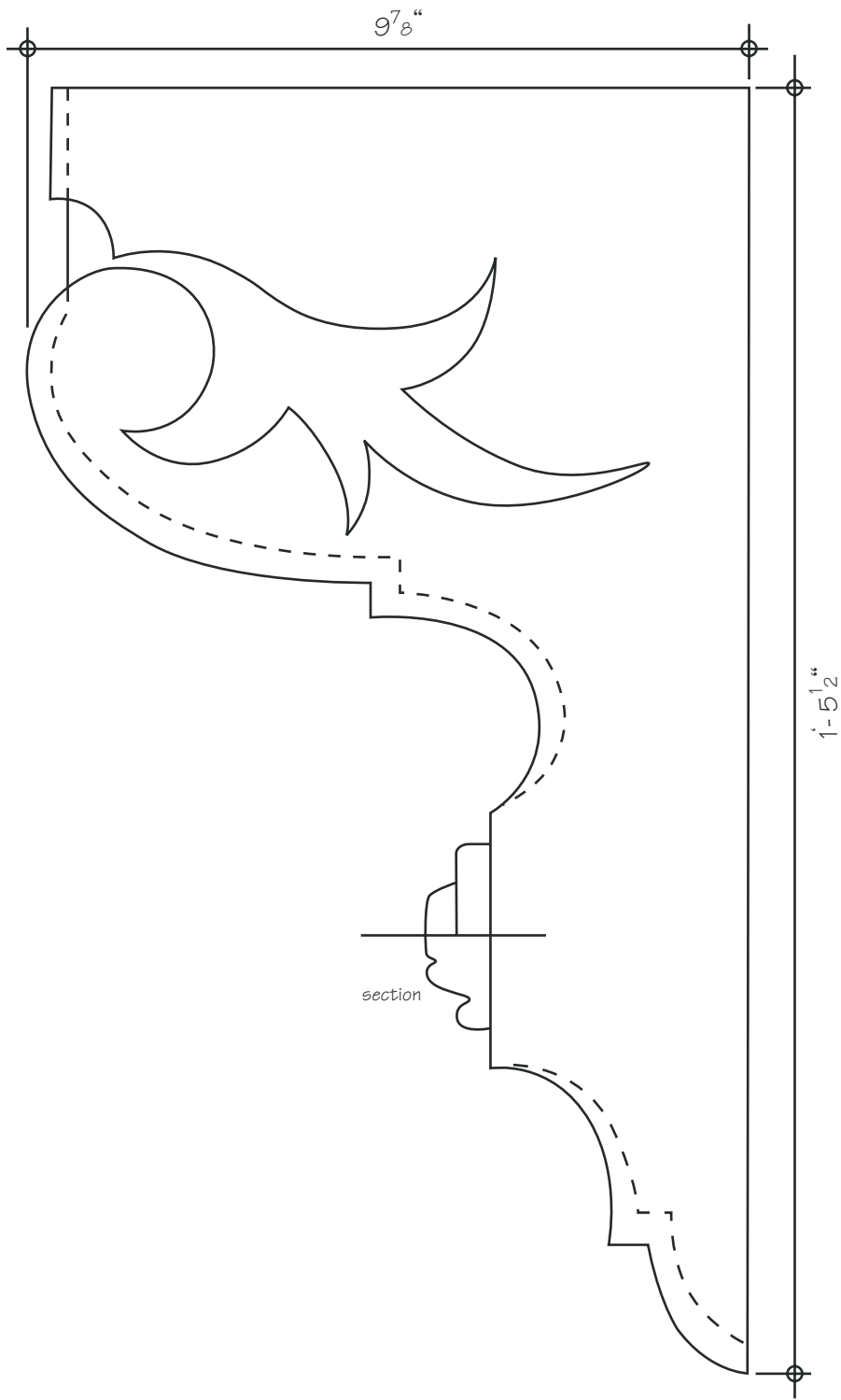

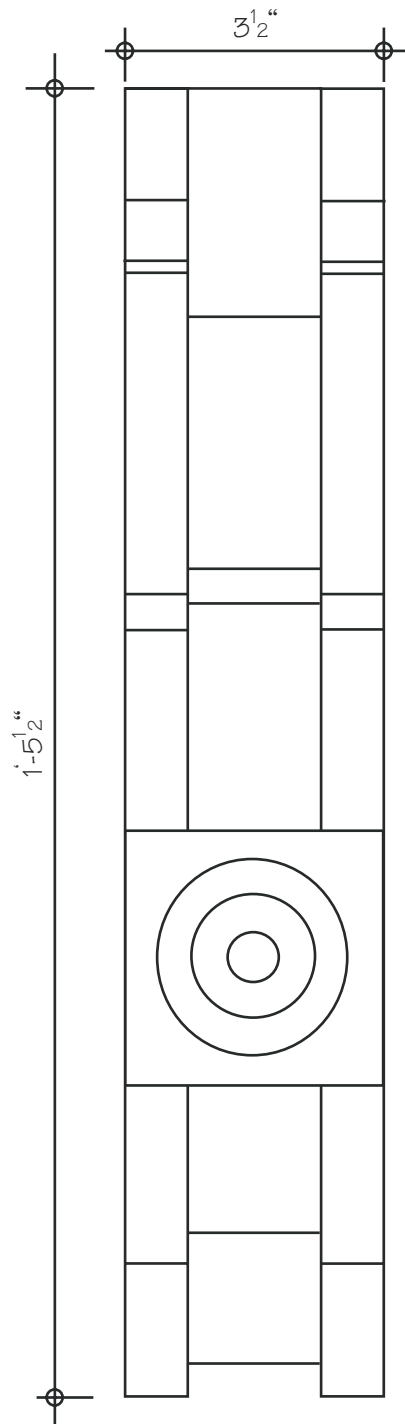

ELEVATION

