

**Appendix:**  
(details from *The Heritage Look*)

**A. Doors** ..... 41

**B. Doorways** ..... 69

**C. Brackets** ..... 84

**D. Windows** ..... 94

## **Appendix A:**

### **Doors**

The doors illustrated were selected because they are found more than once in the Heritage Conservation Area, and because they reflect the builder's choice of designs popular after the great fire of 1892. Many are repeated throughout the area, others are found in isolated groupings, sometimes appearing in one range of buildings only. The common material is select pine.

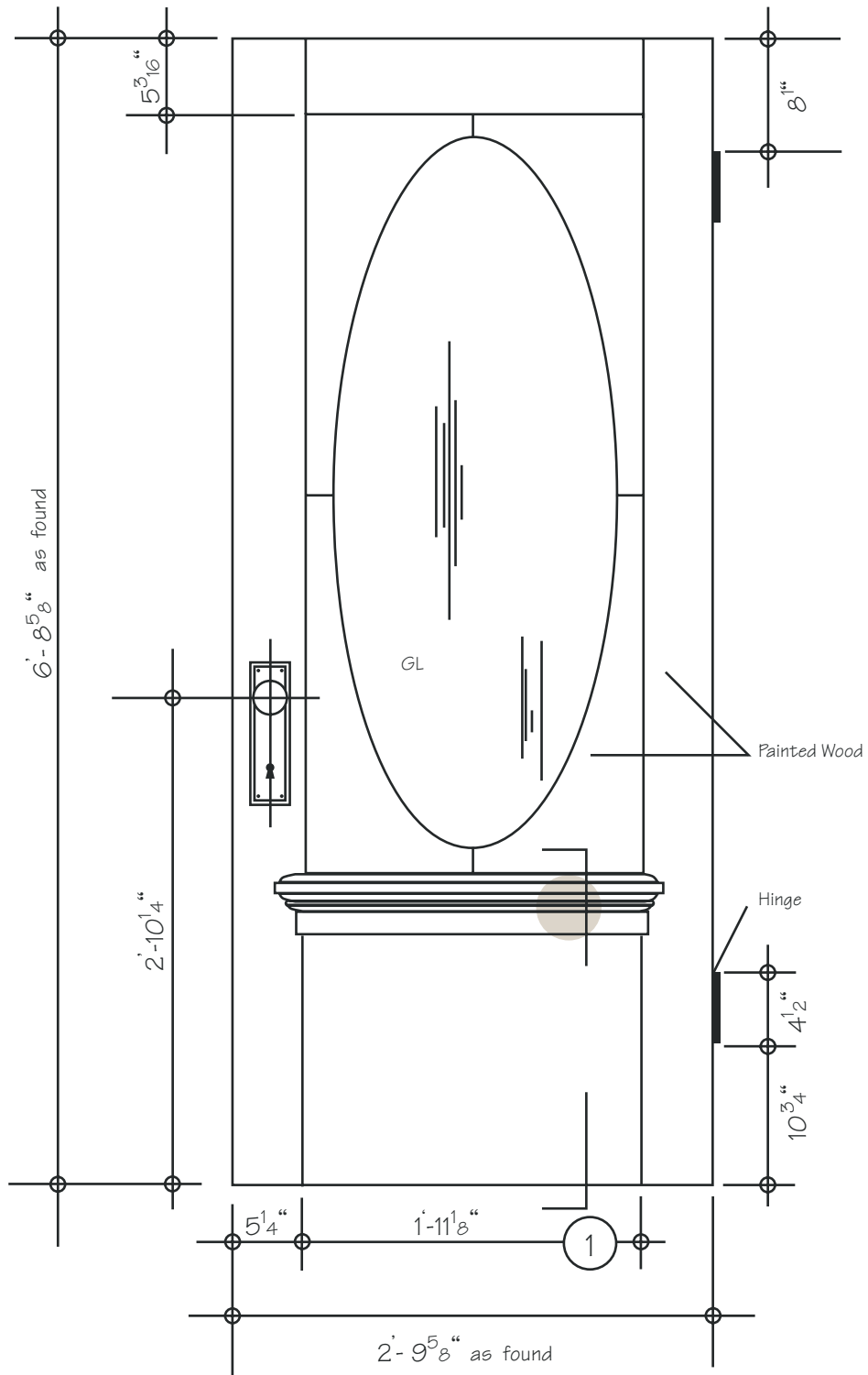

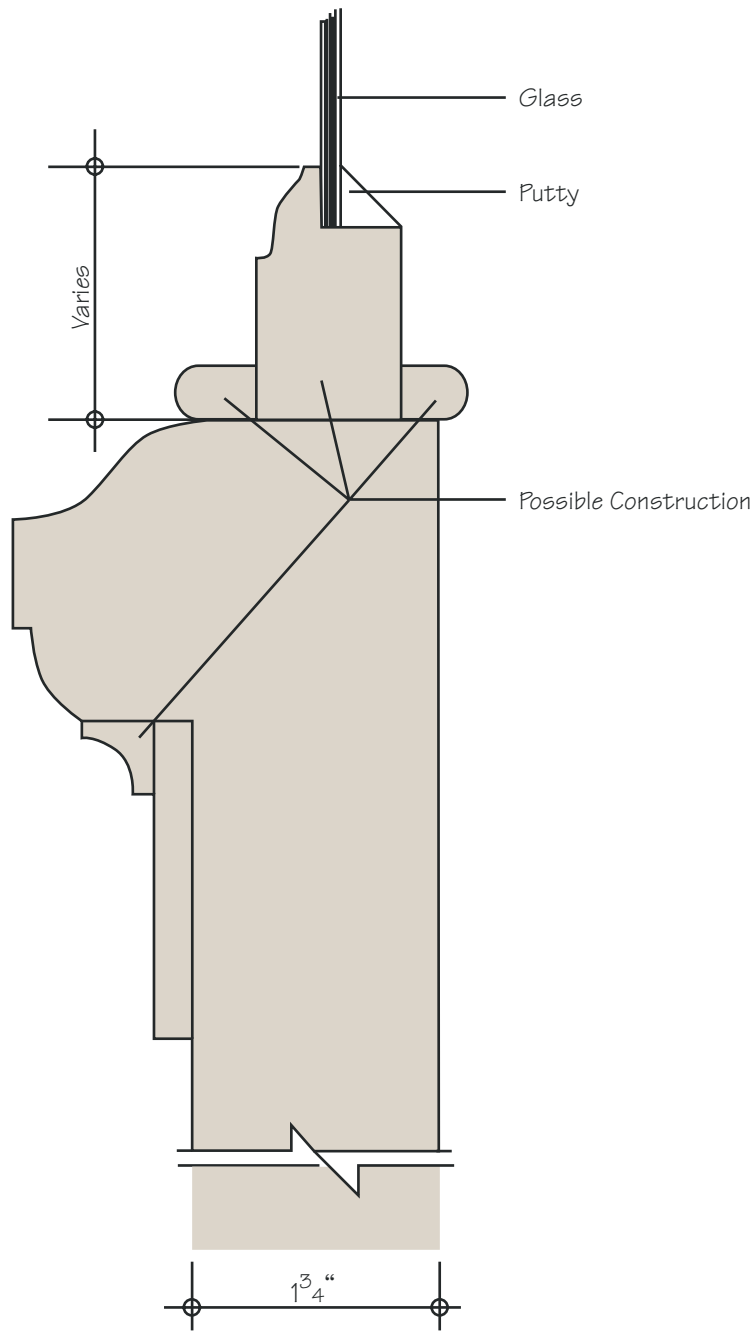

Section 1 Bottom Rail

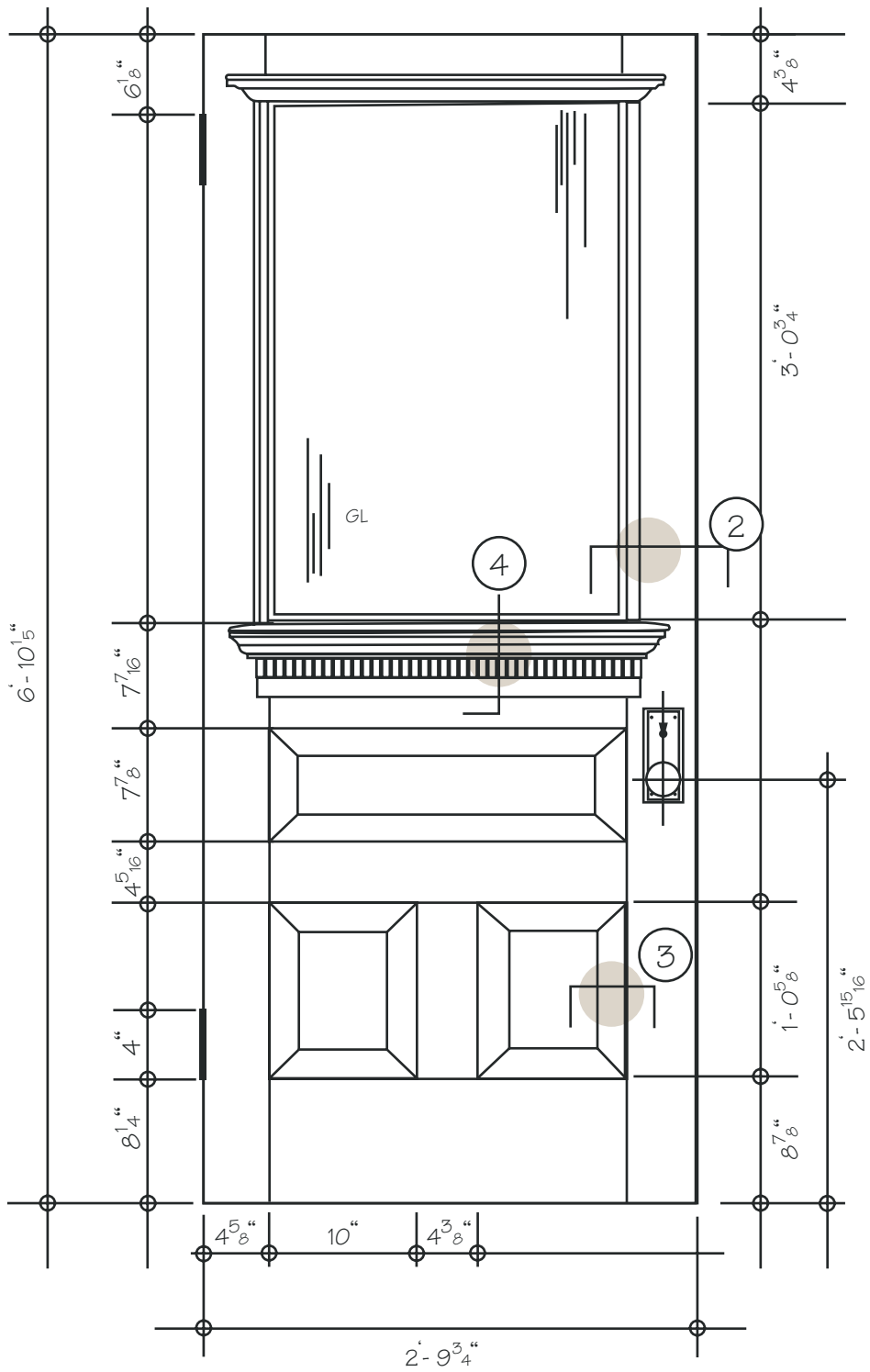

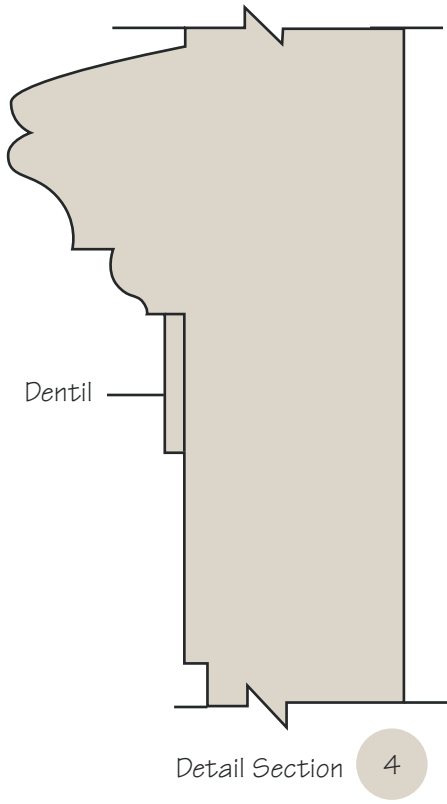
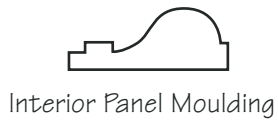
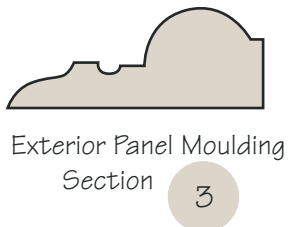
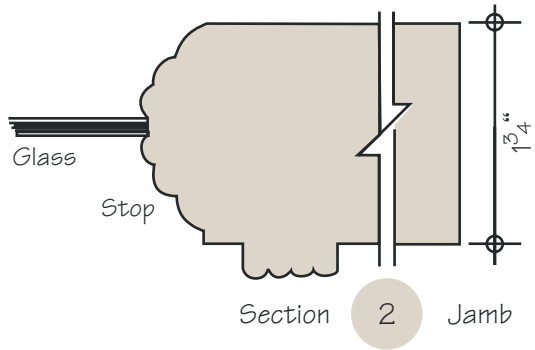

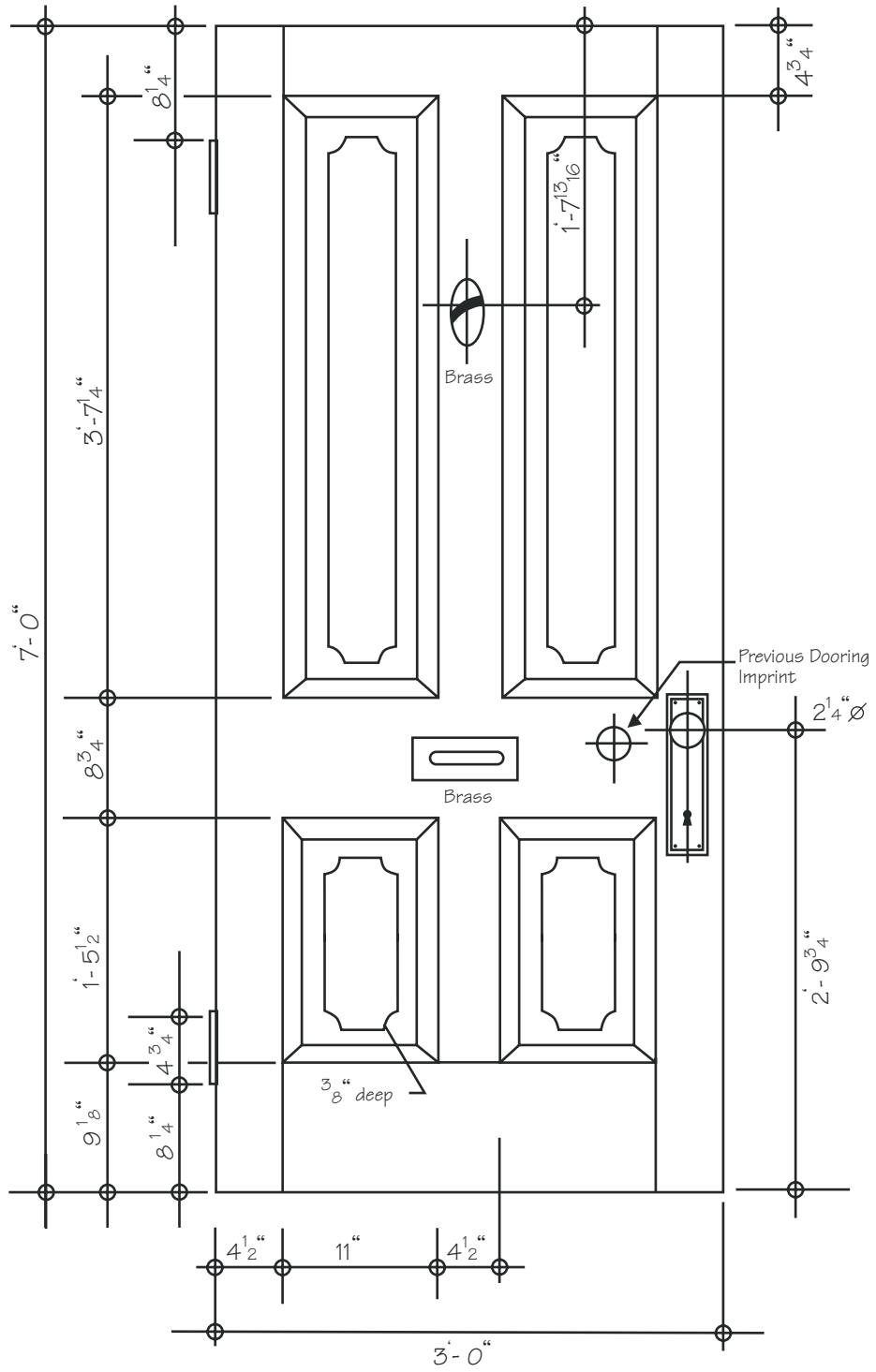

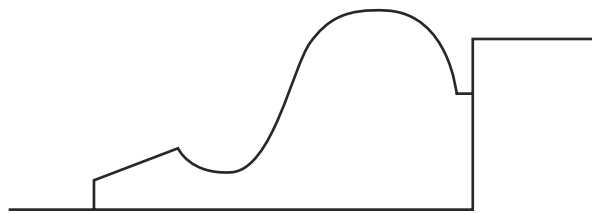

Interior Panel Moulding  
(Interior panels have no  
raised field decoration)

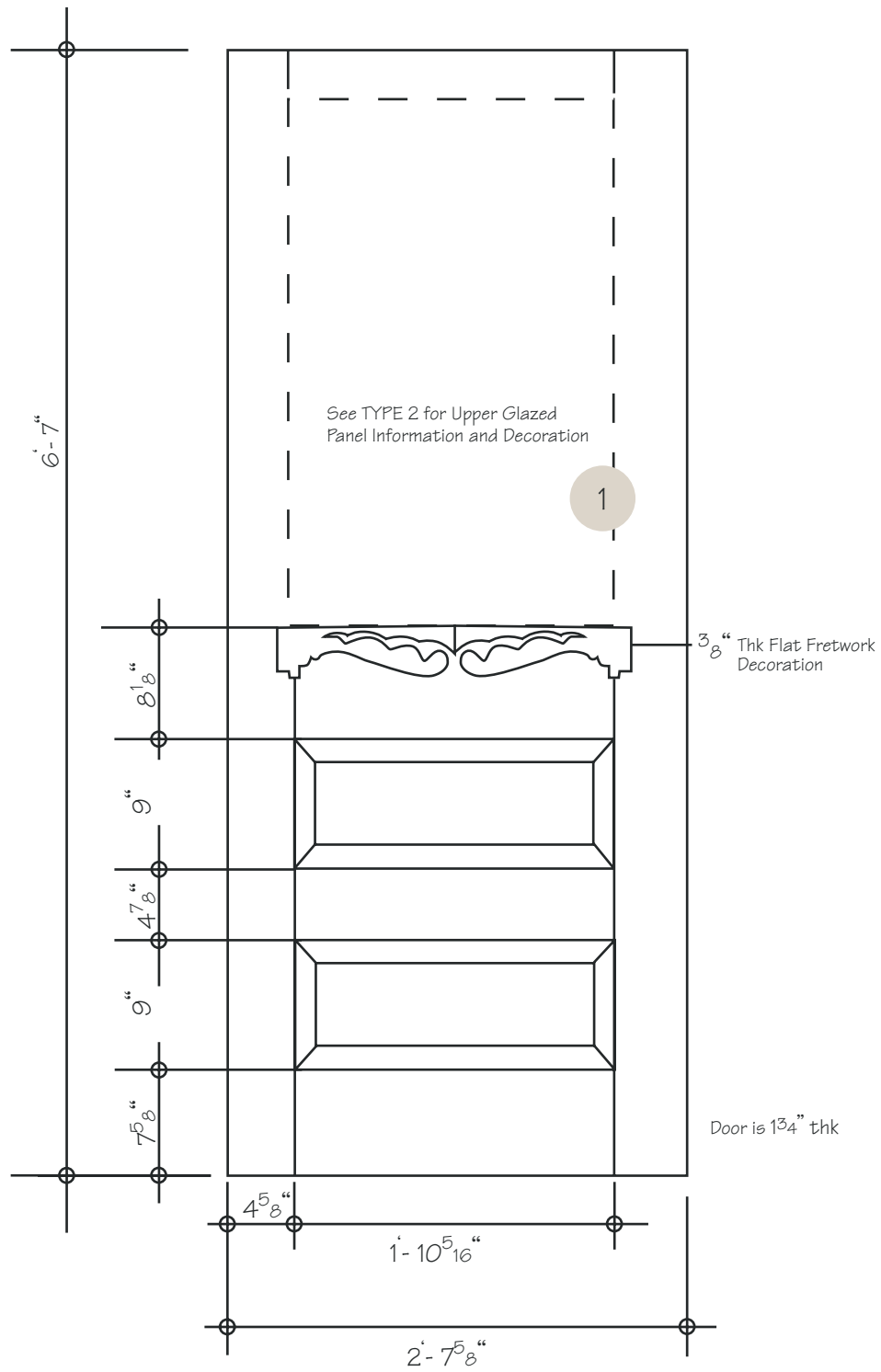

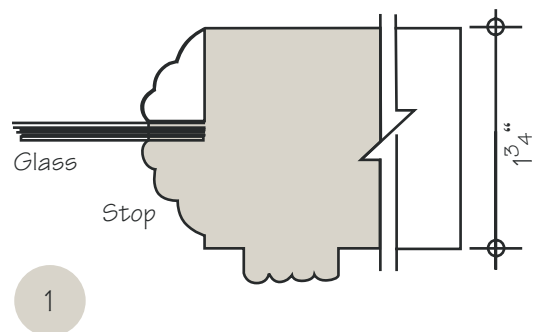

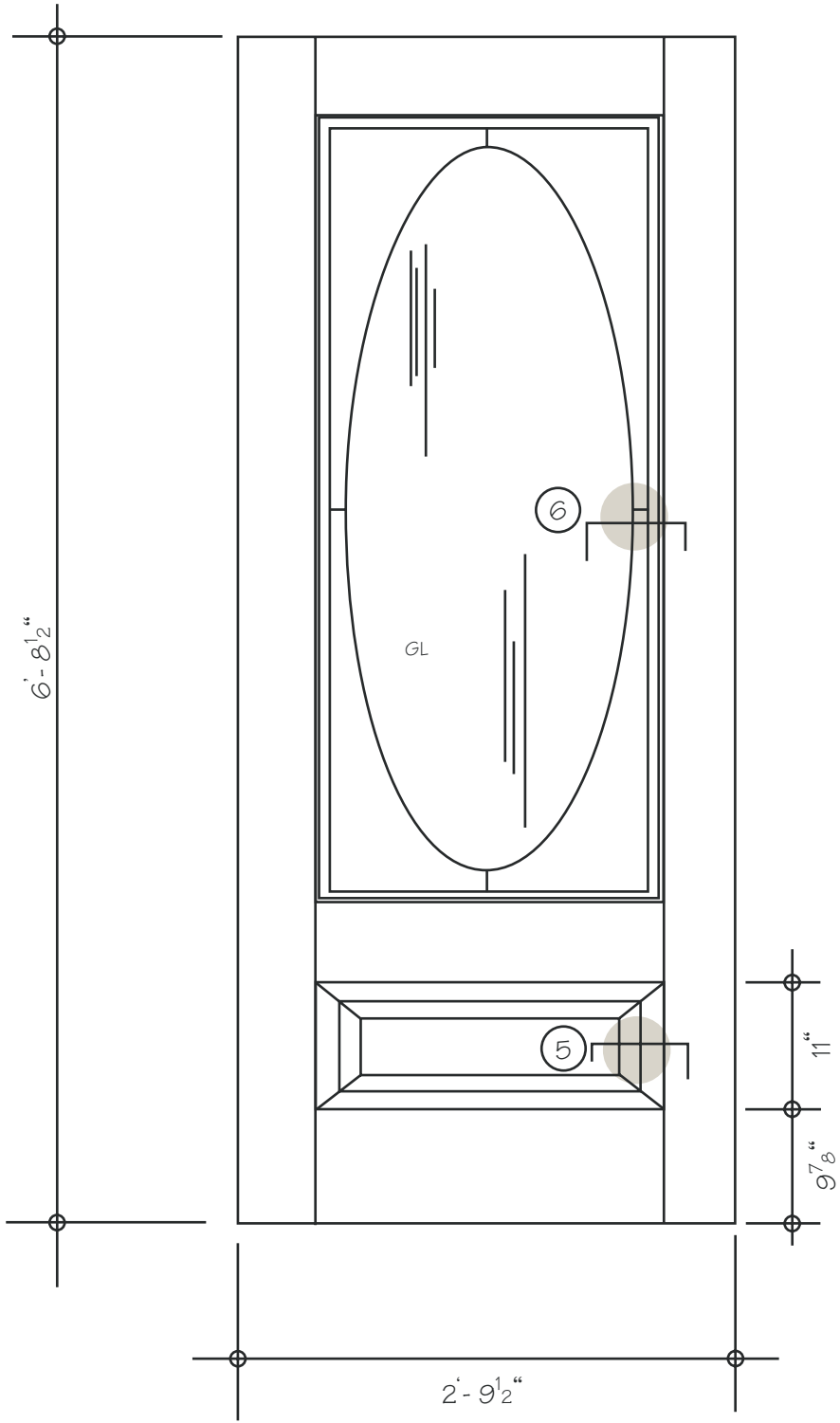

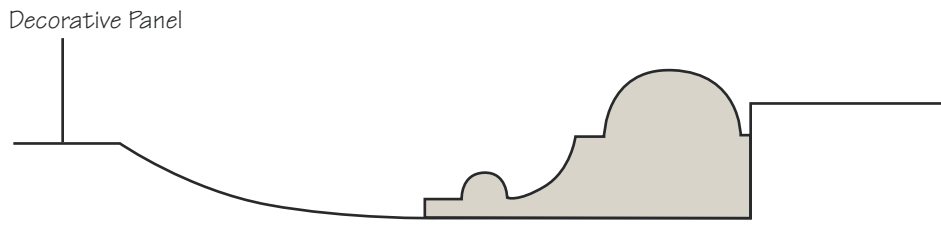

Moulding- Glazed Panel Section 5

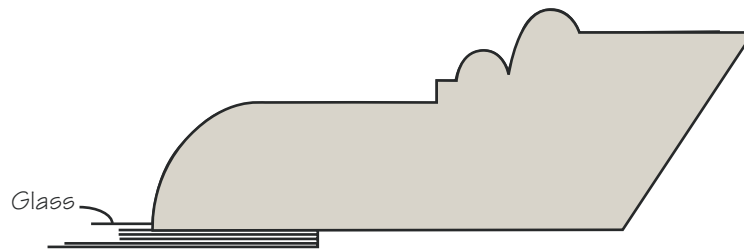

Spandrel Moulding Exterior

6



Glazing stop-Interior

(This moulding is in four parts and cut to follow the elliptical glass shape.)

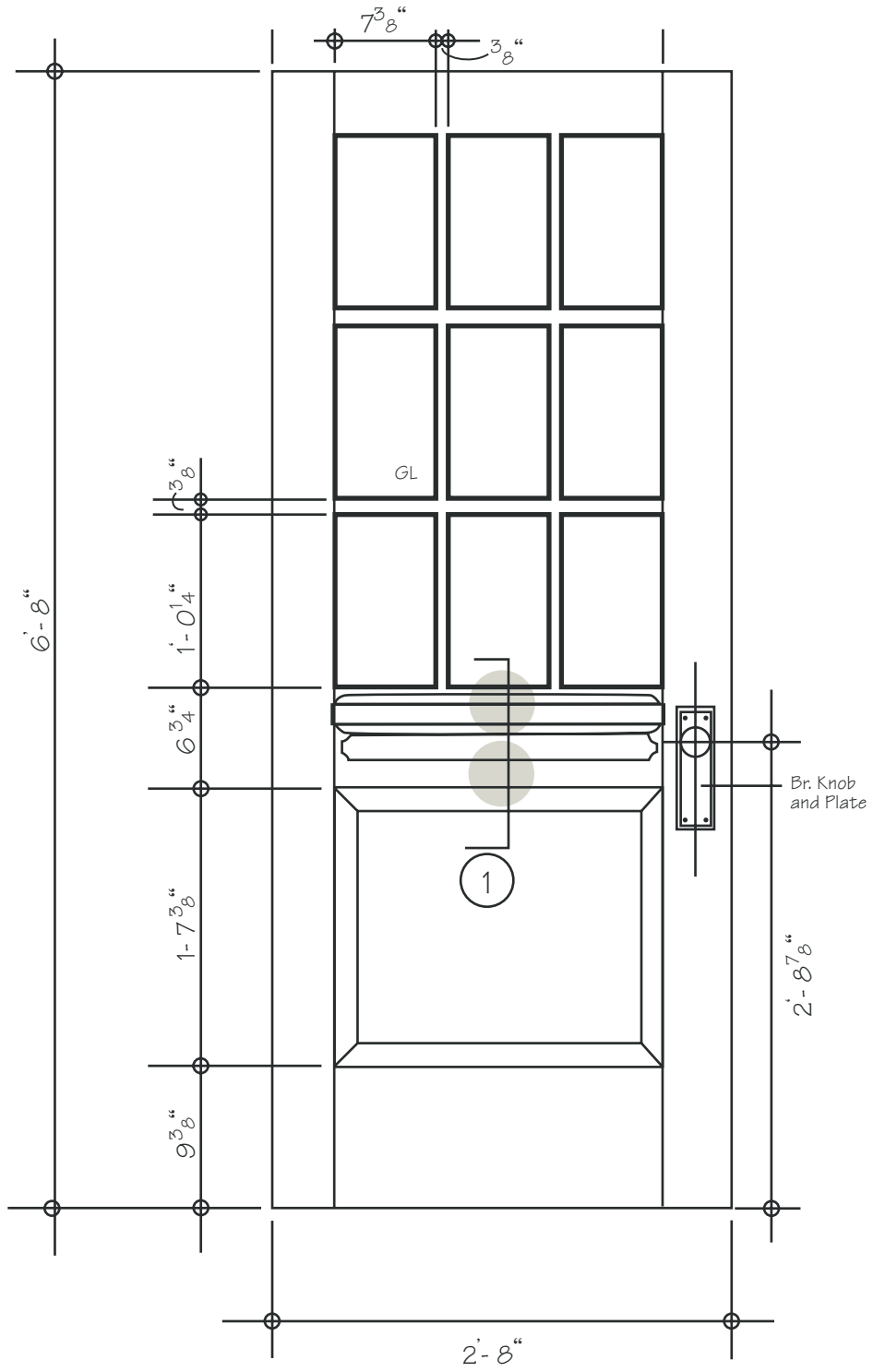

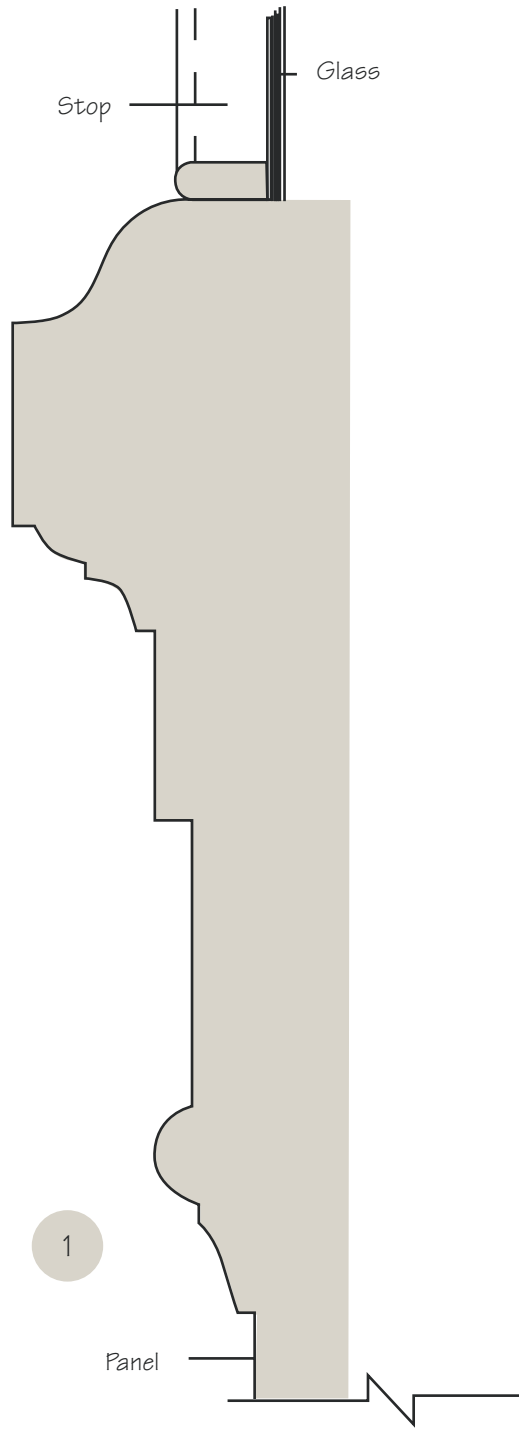

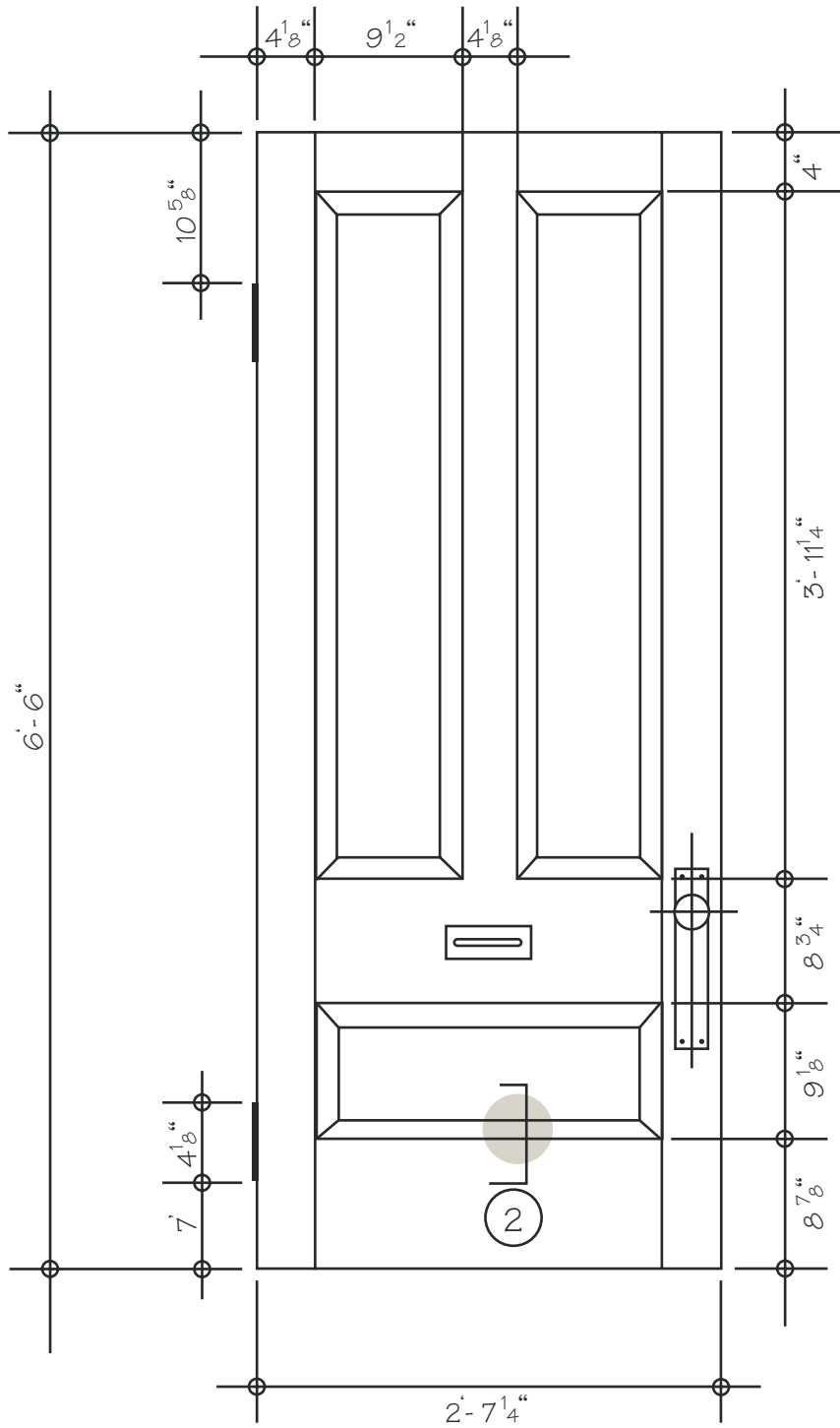

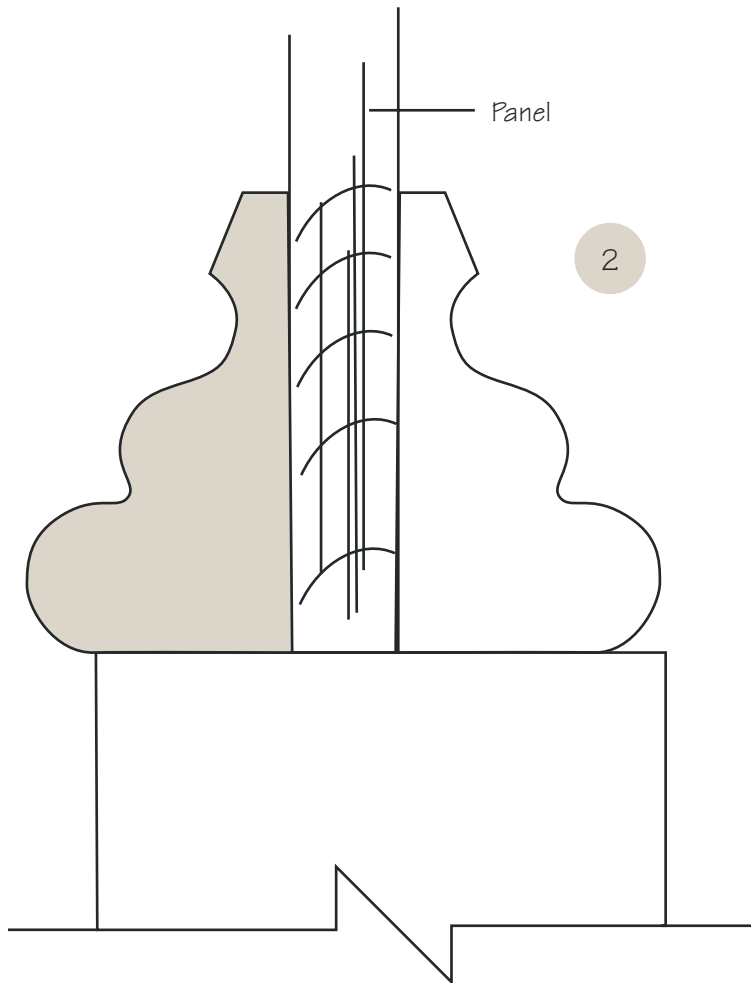

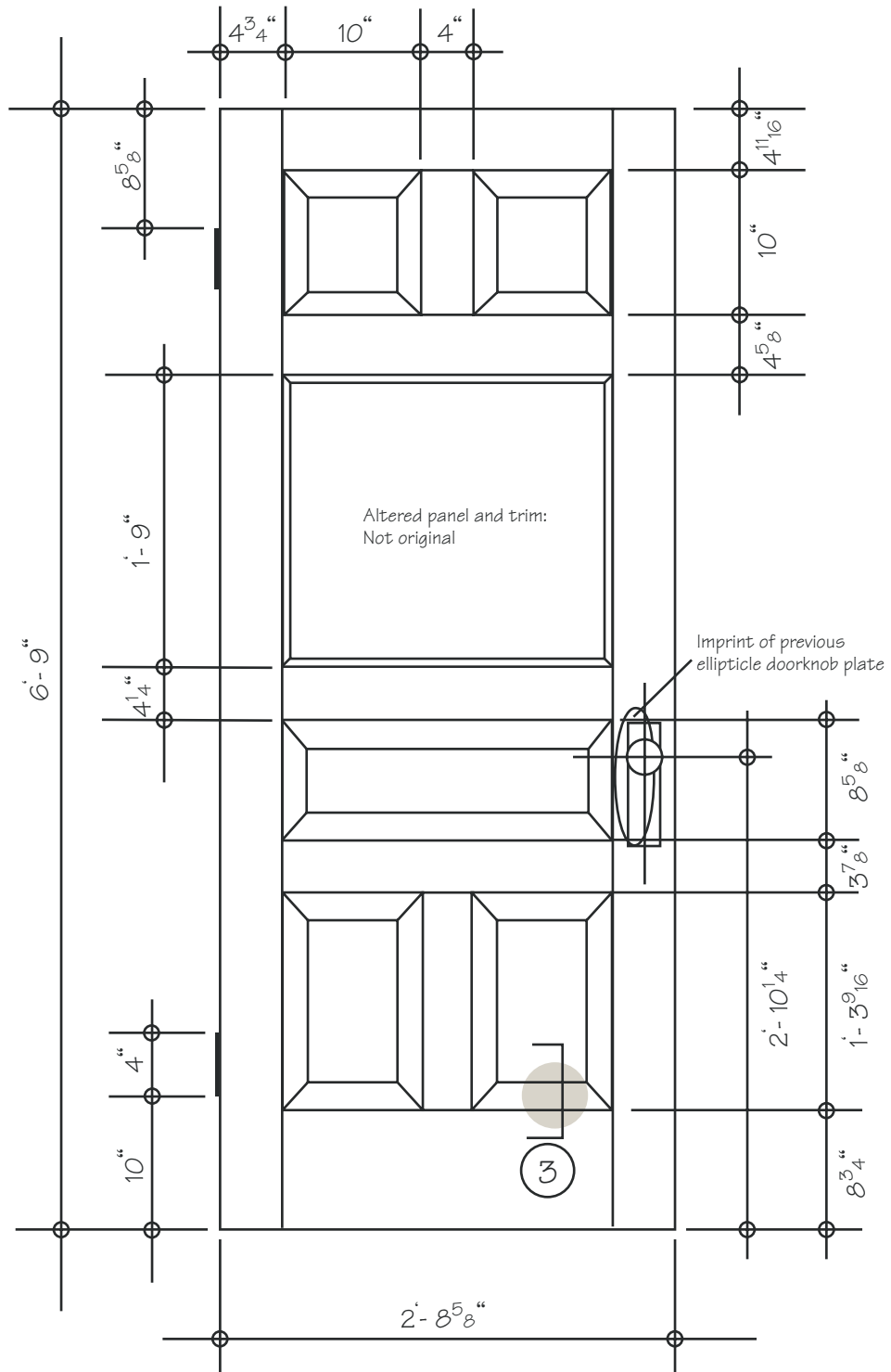

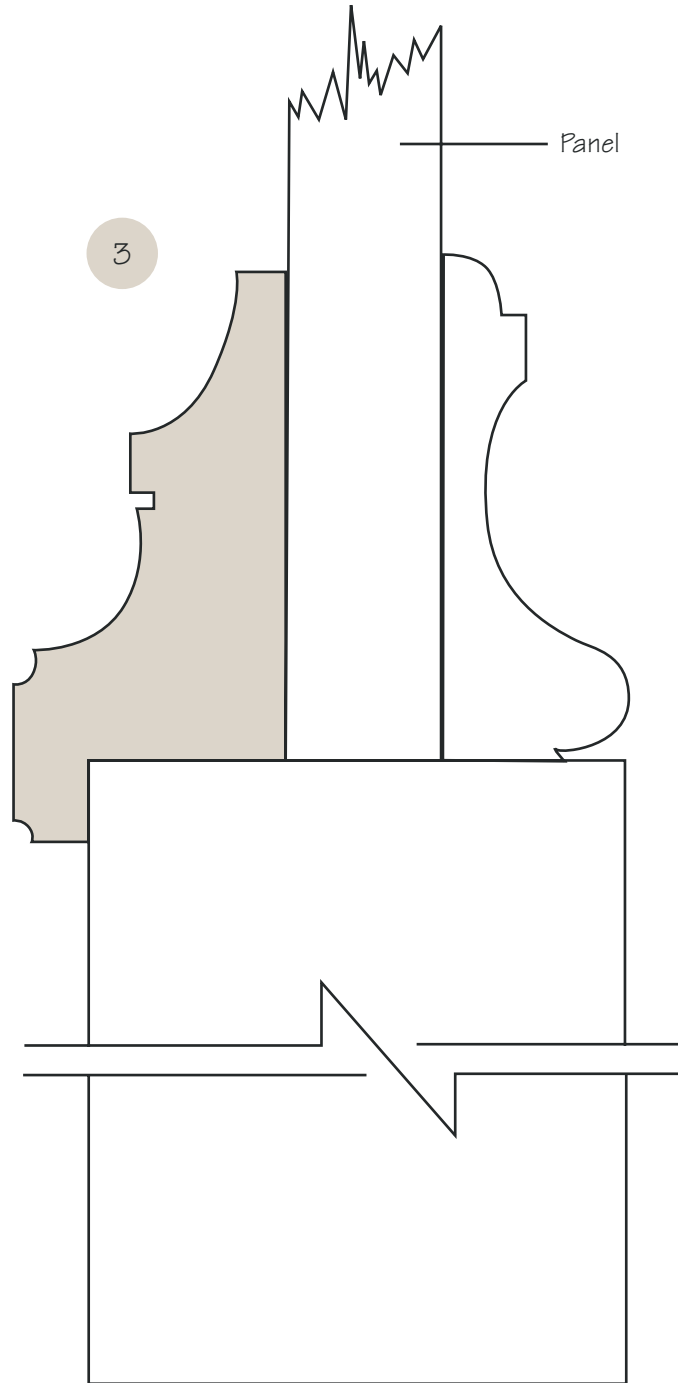

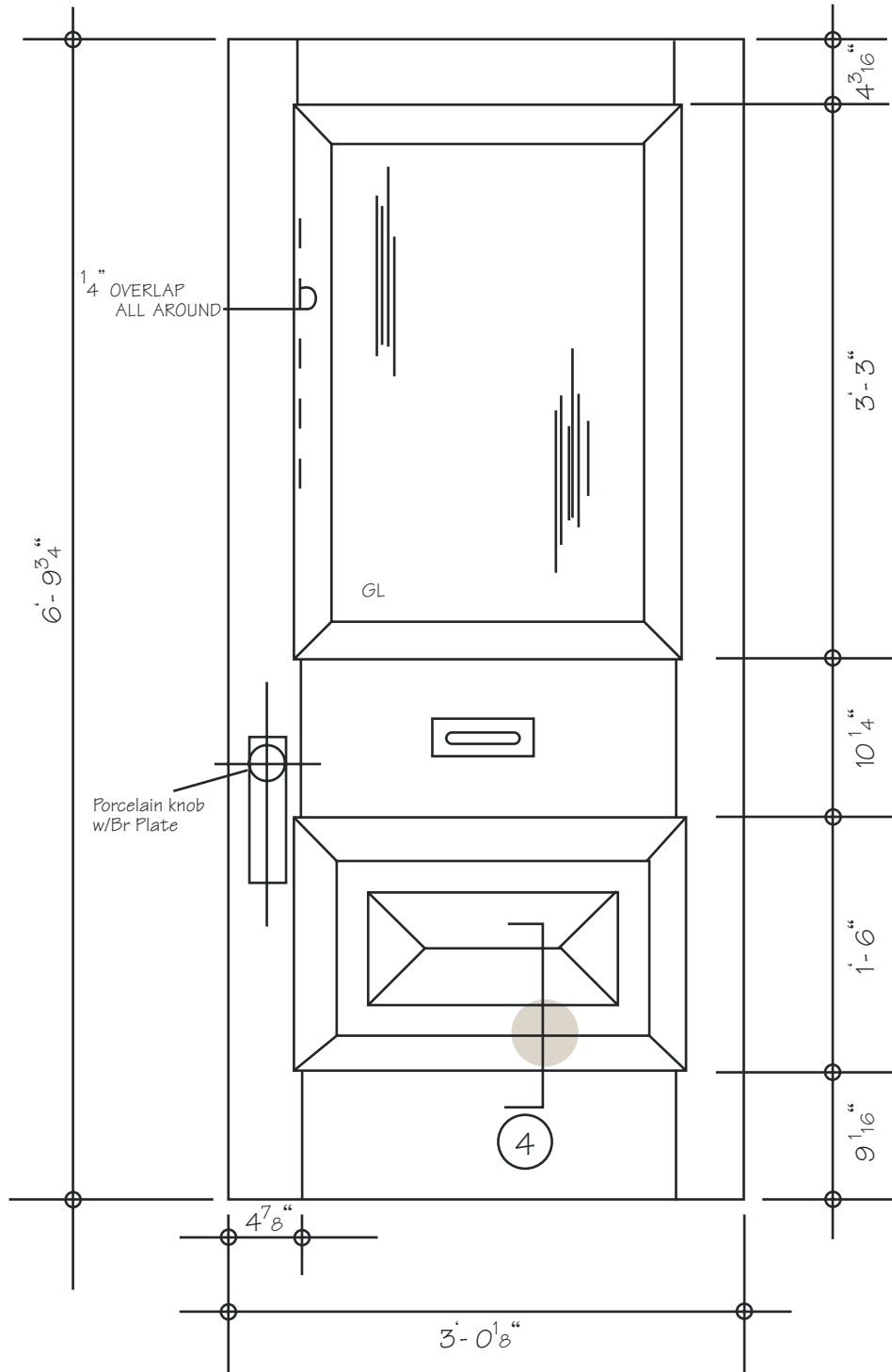

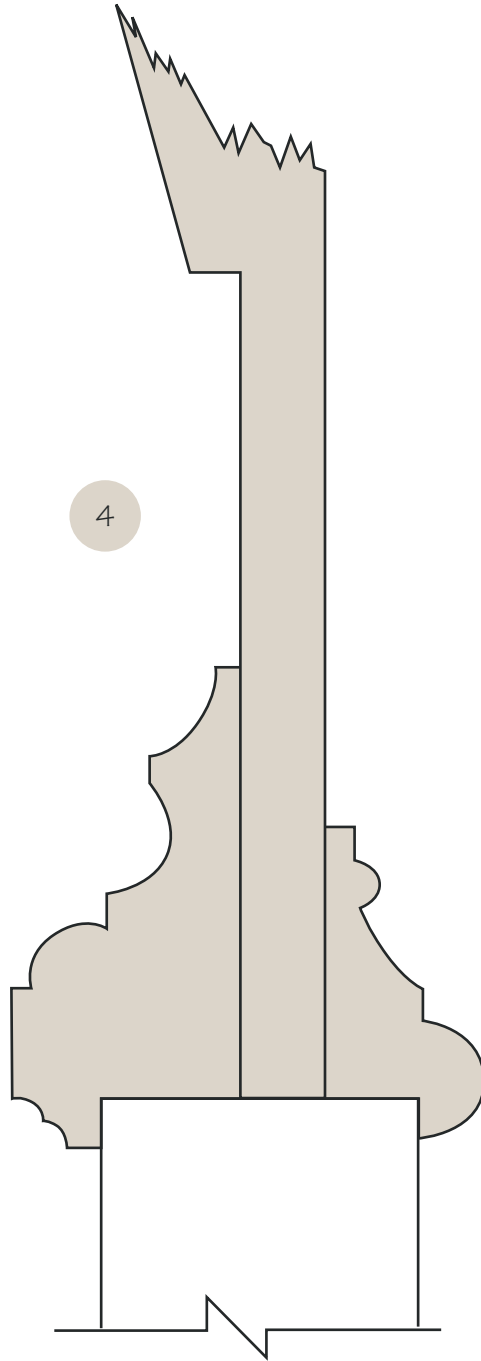

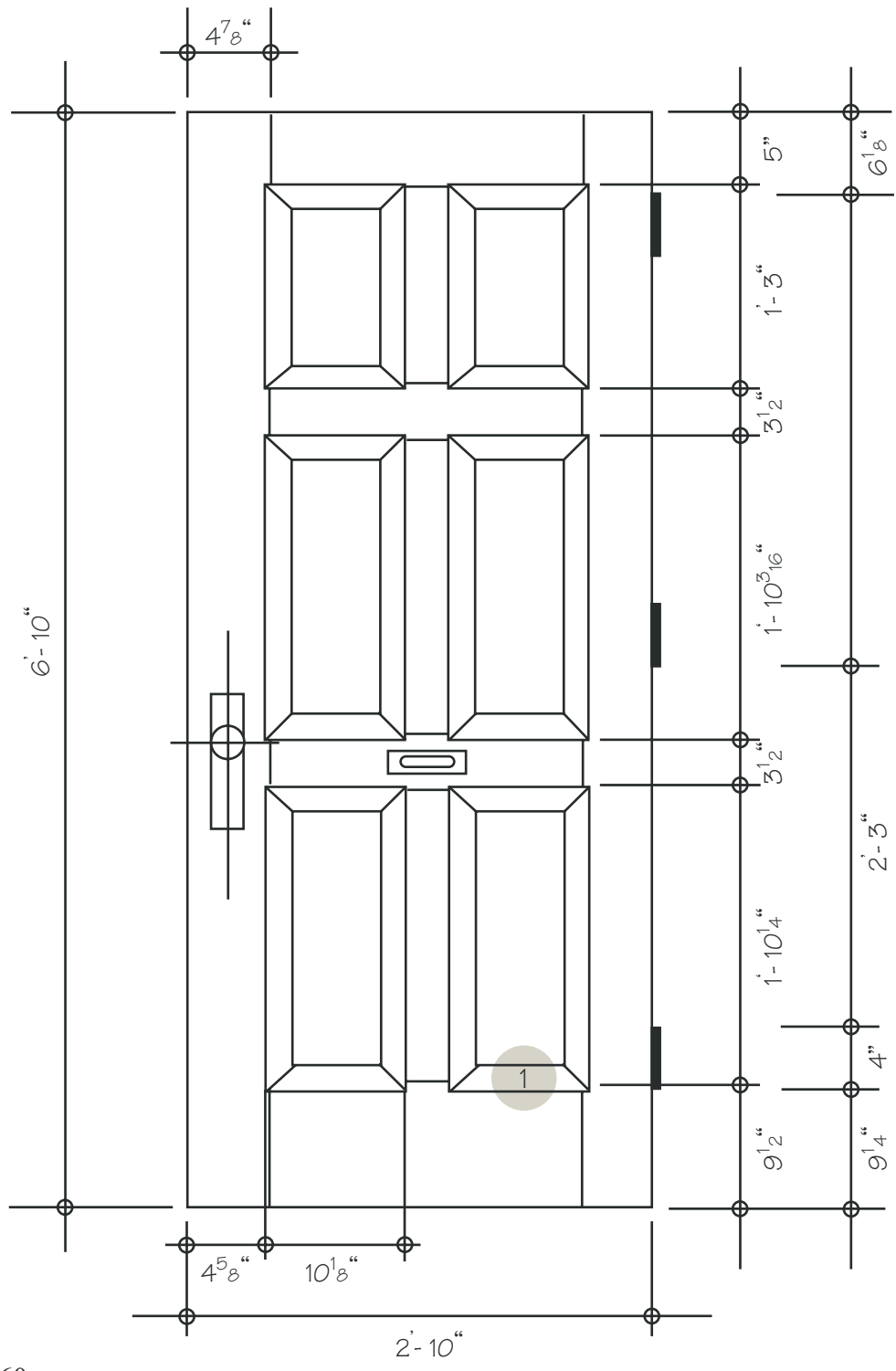

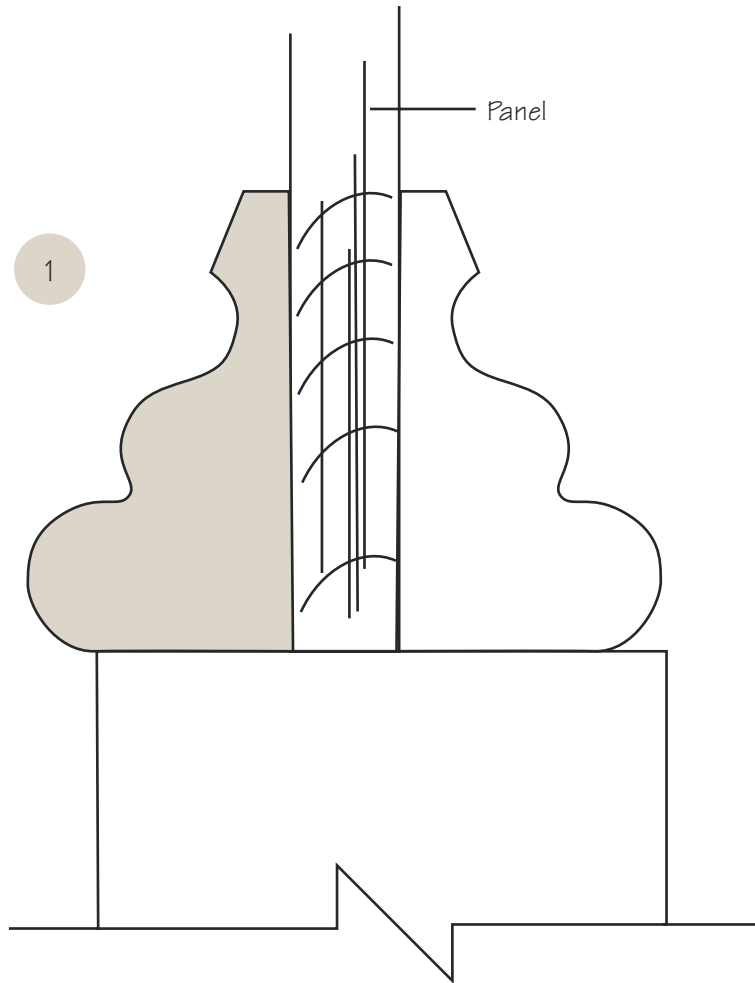

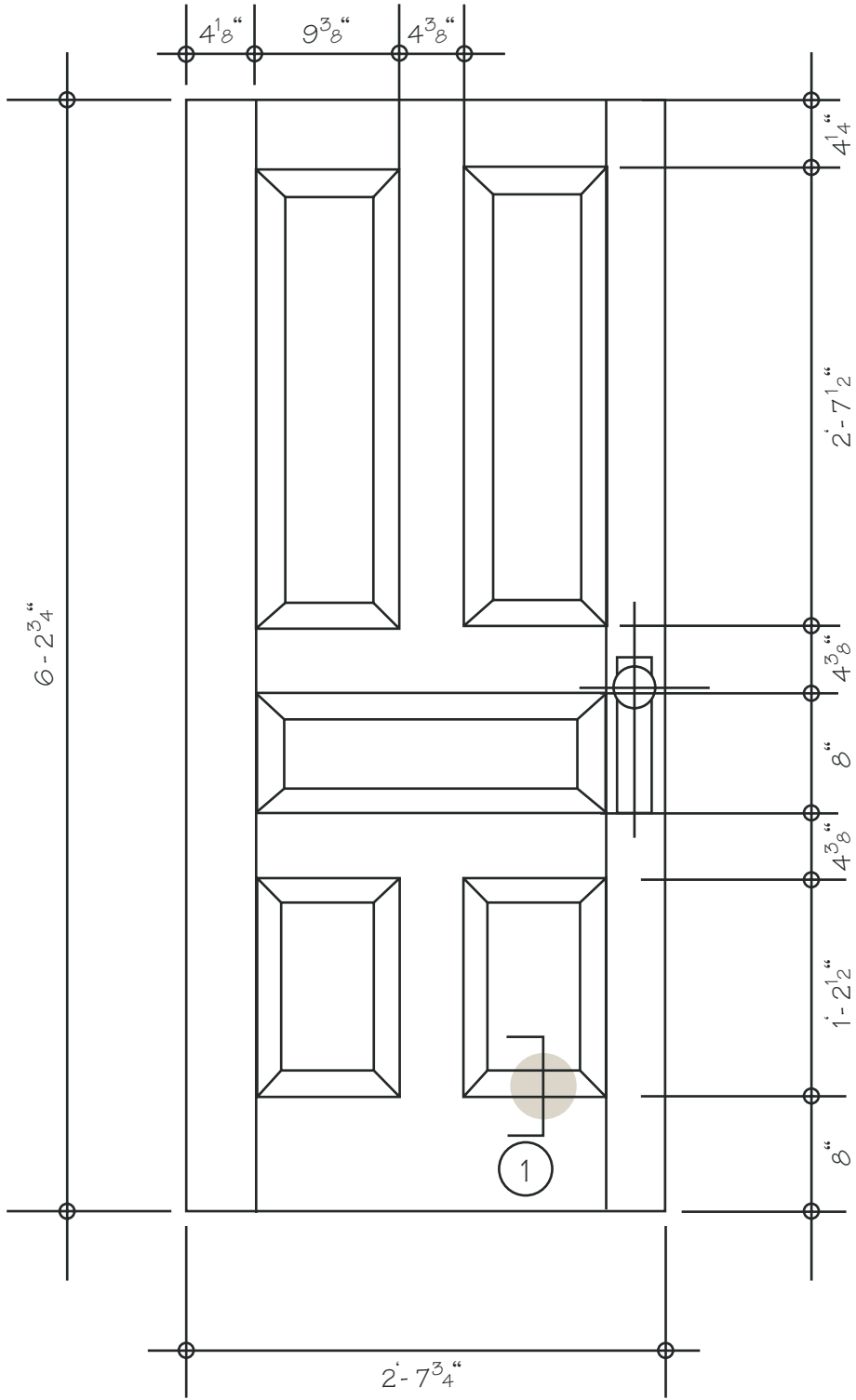

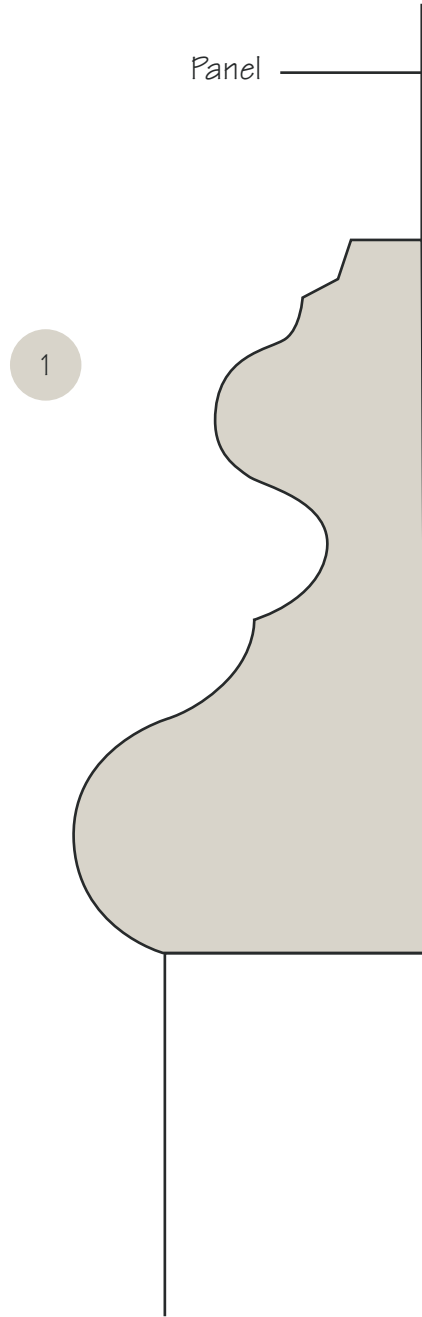

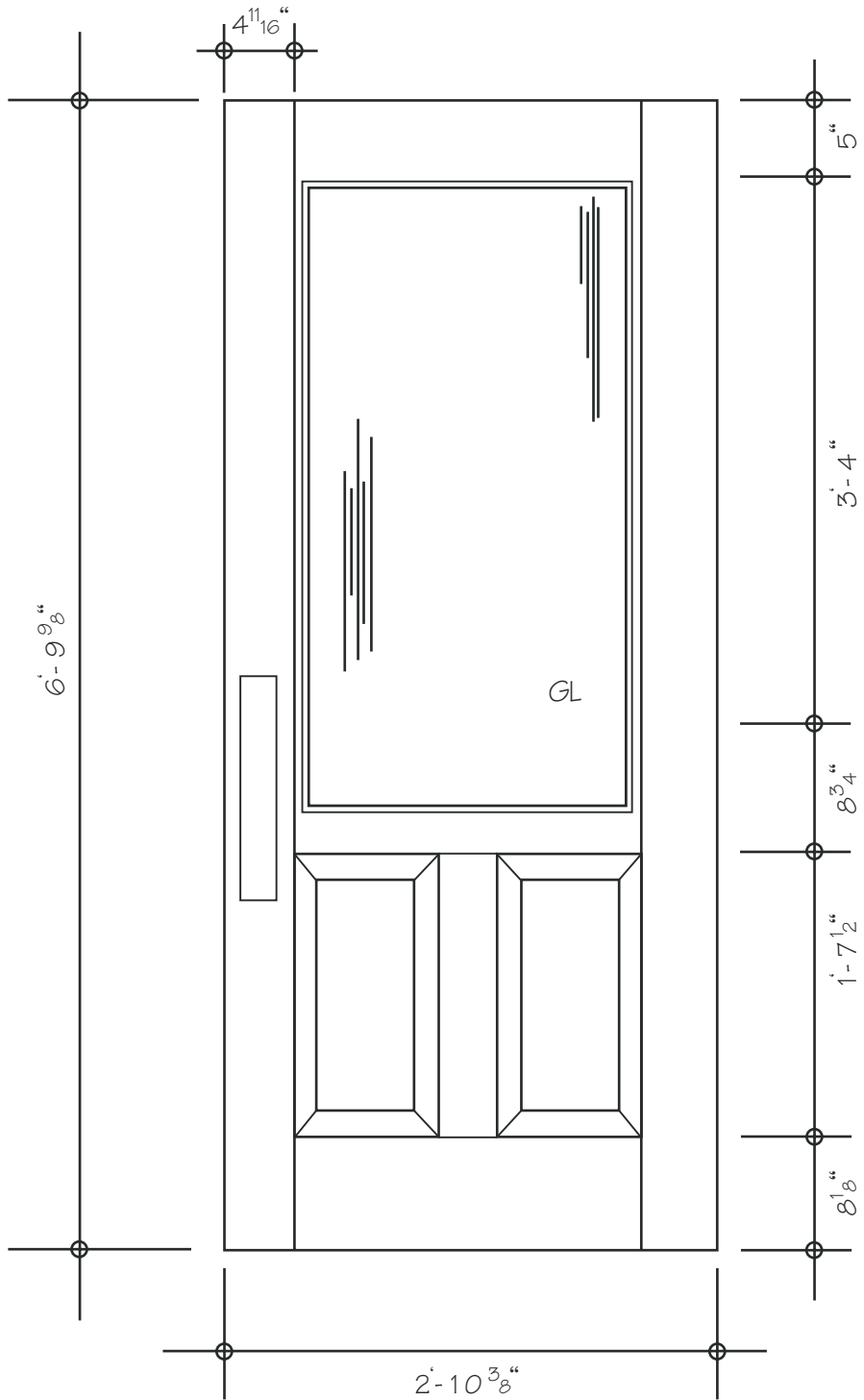

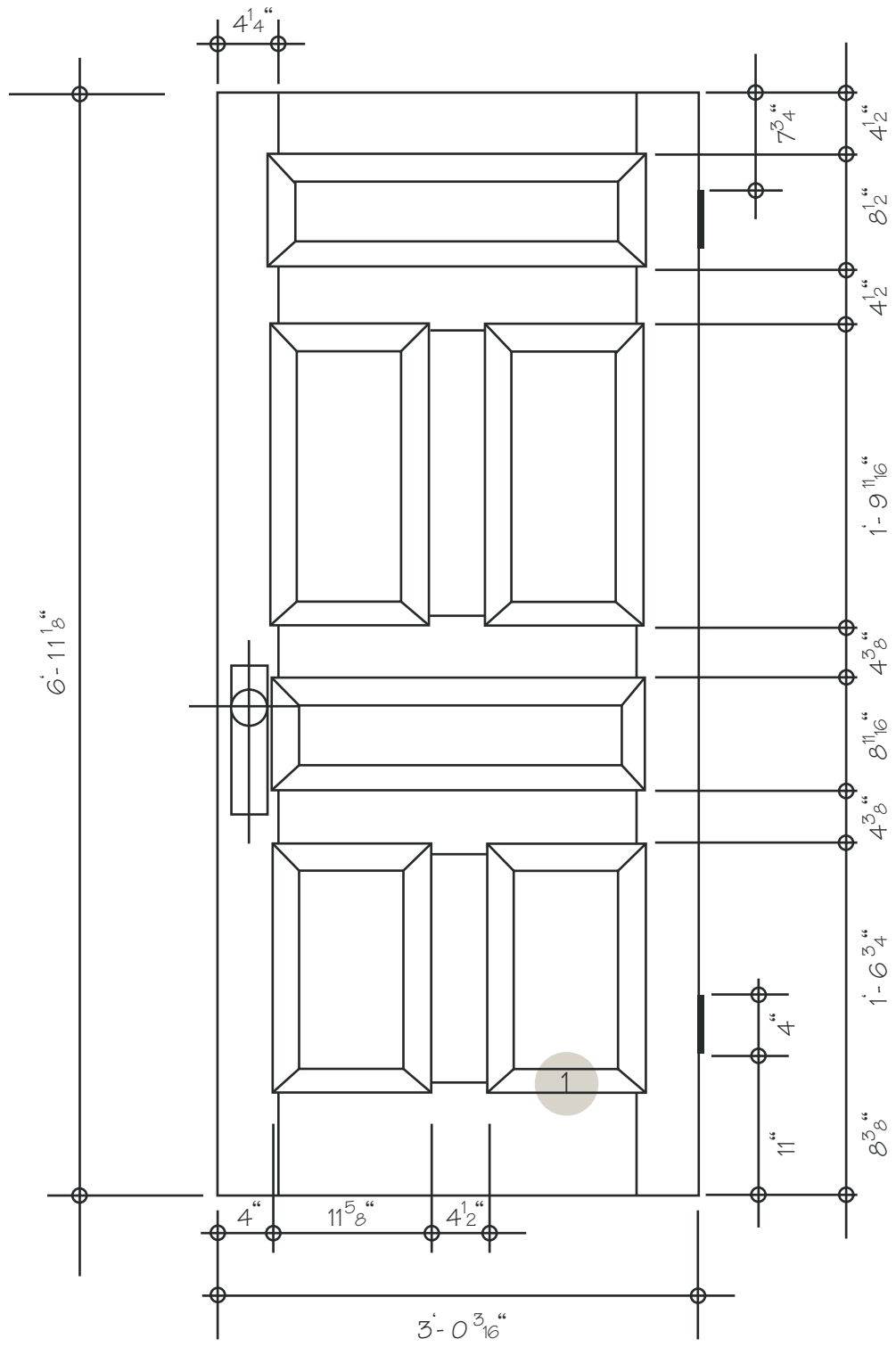

TYPE 13

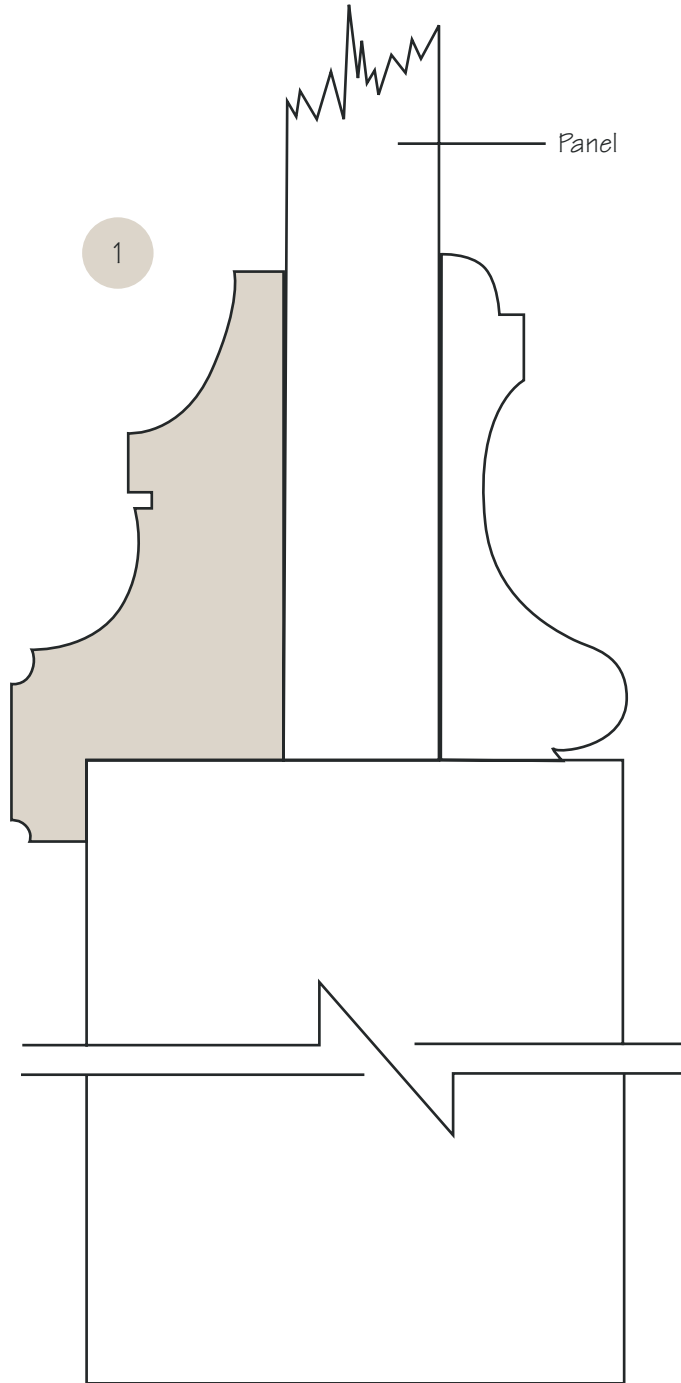

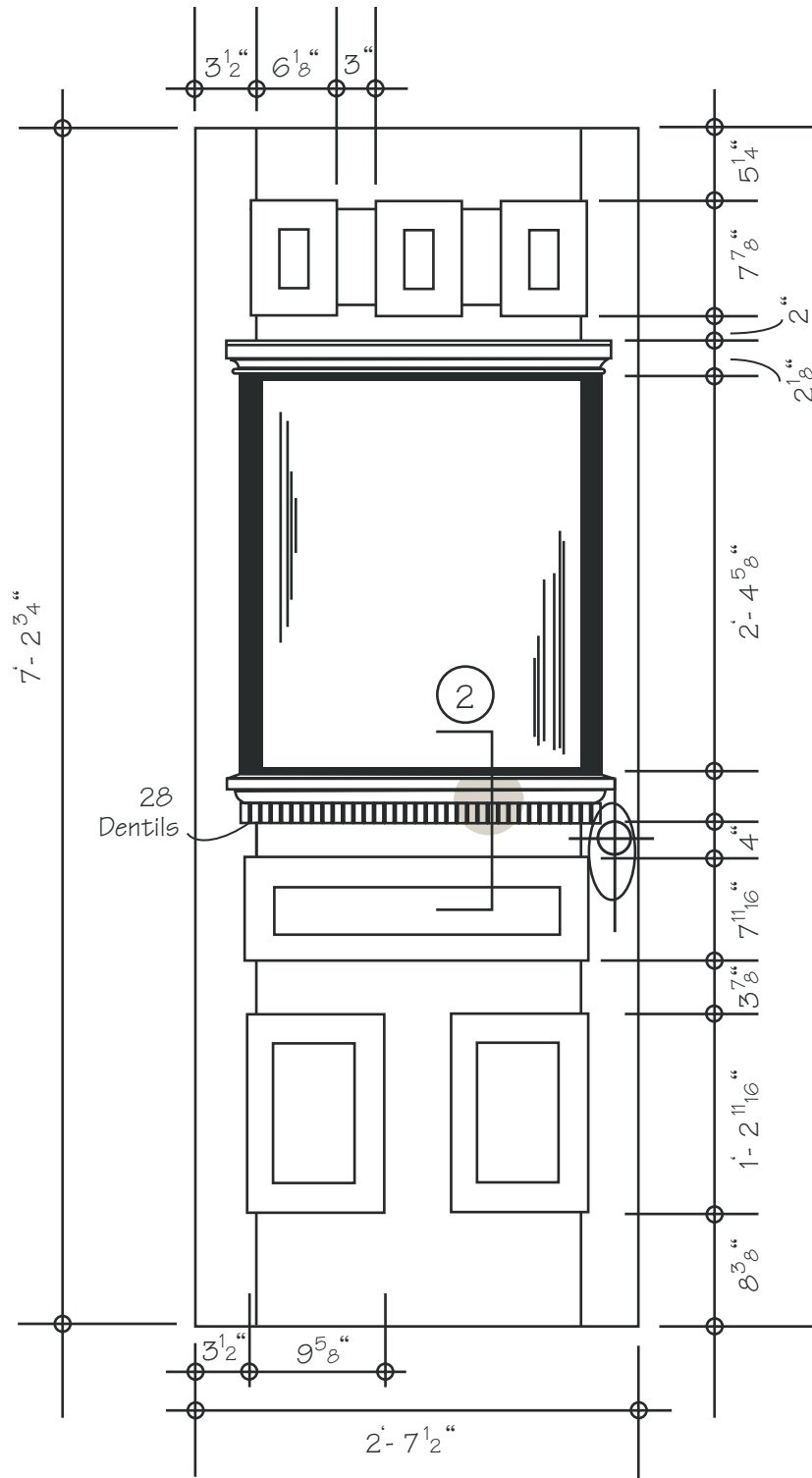

TYPE 14

