

Appendix B:

Doorways

The main entrance is the most important architectural feature in the façade of range houses. The doorway had much care lavished on the design of paneling and mouldings to form a frame for the front door and in many cases the proportions reflect an earlier and more classic approach to design than the rest of the exterior of the dwelling. Many St. John's houses had storm doors made of 1" x 4" vertical V groove board, sometimes with an additional hinge that permitted only one-third to one-half of the storm door to open in winter. Simple and economical metal thumb latches were used on these doors. These traditional storm doors enhanced local character in old St. John's.

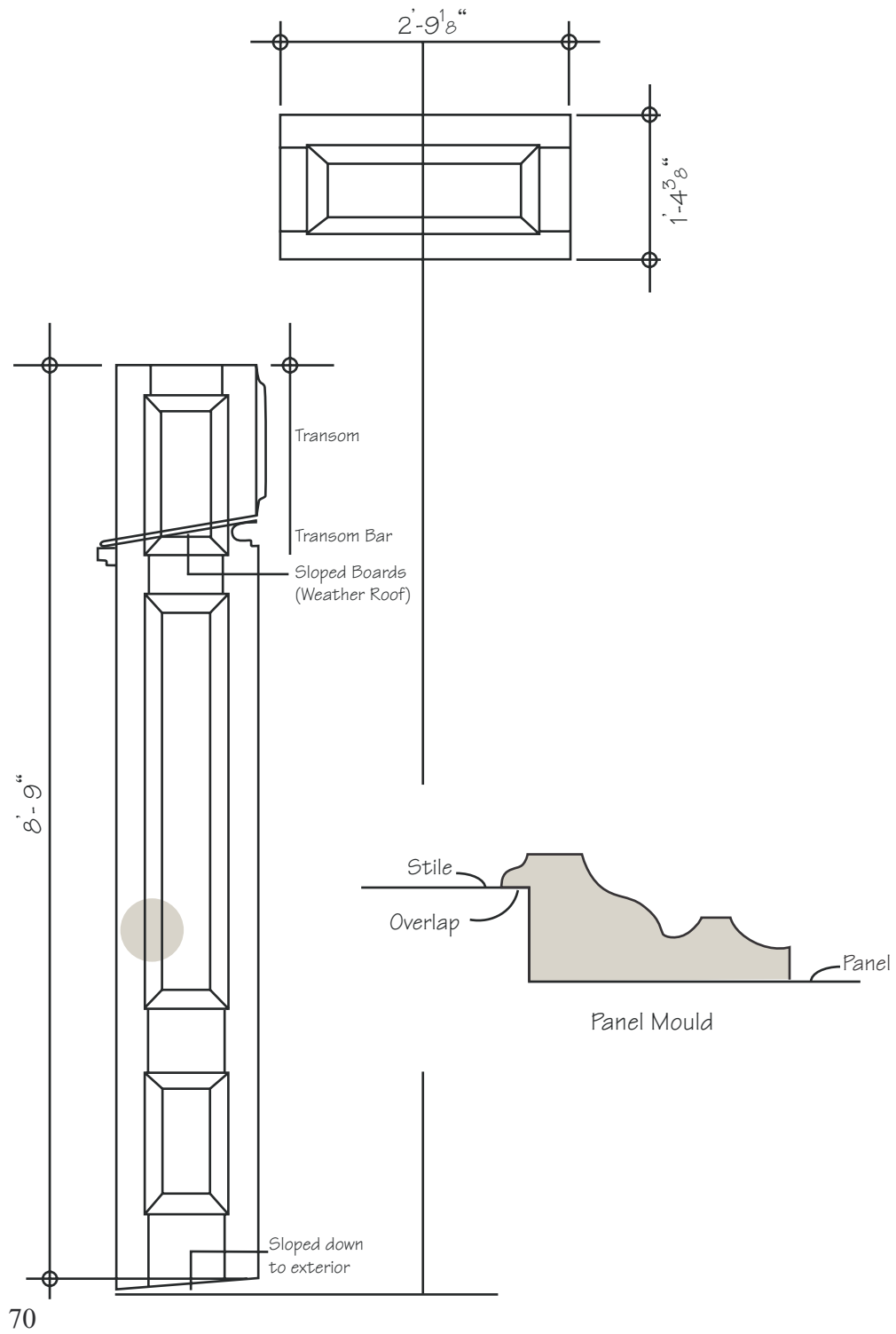

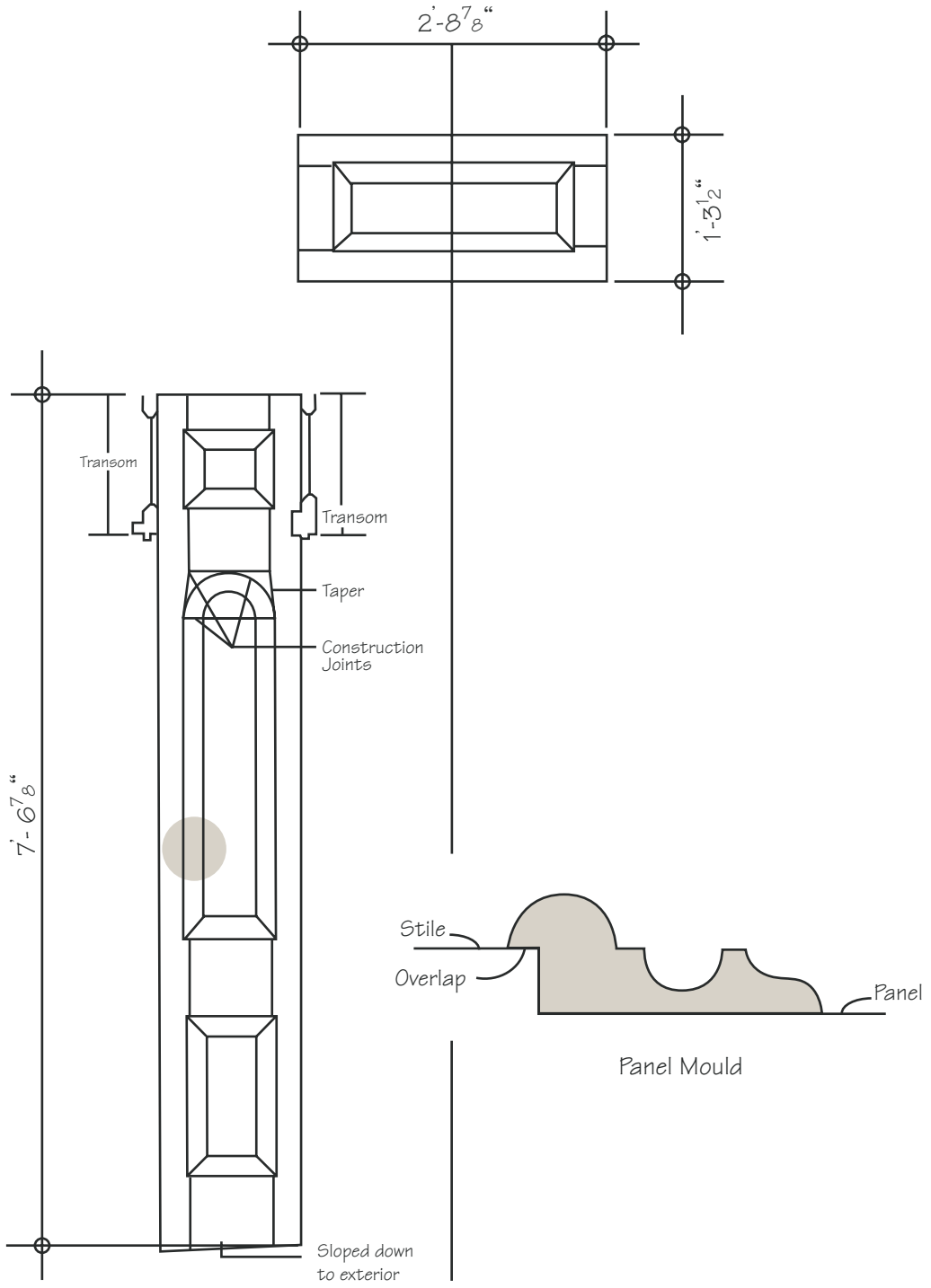

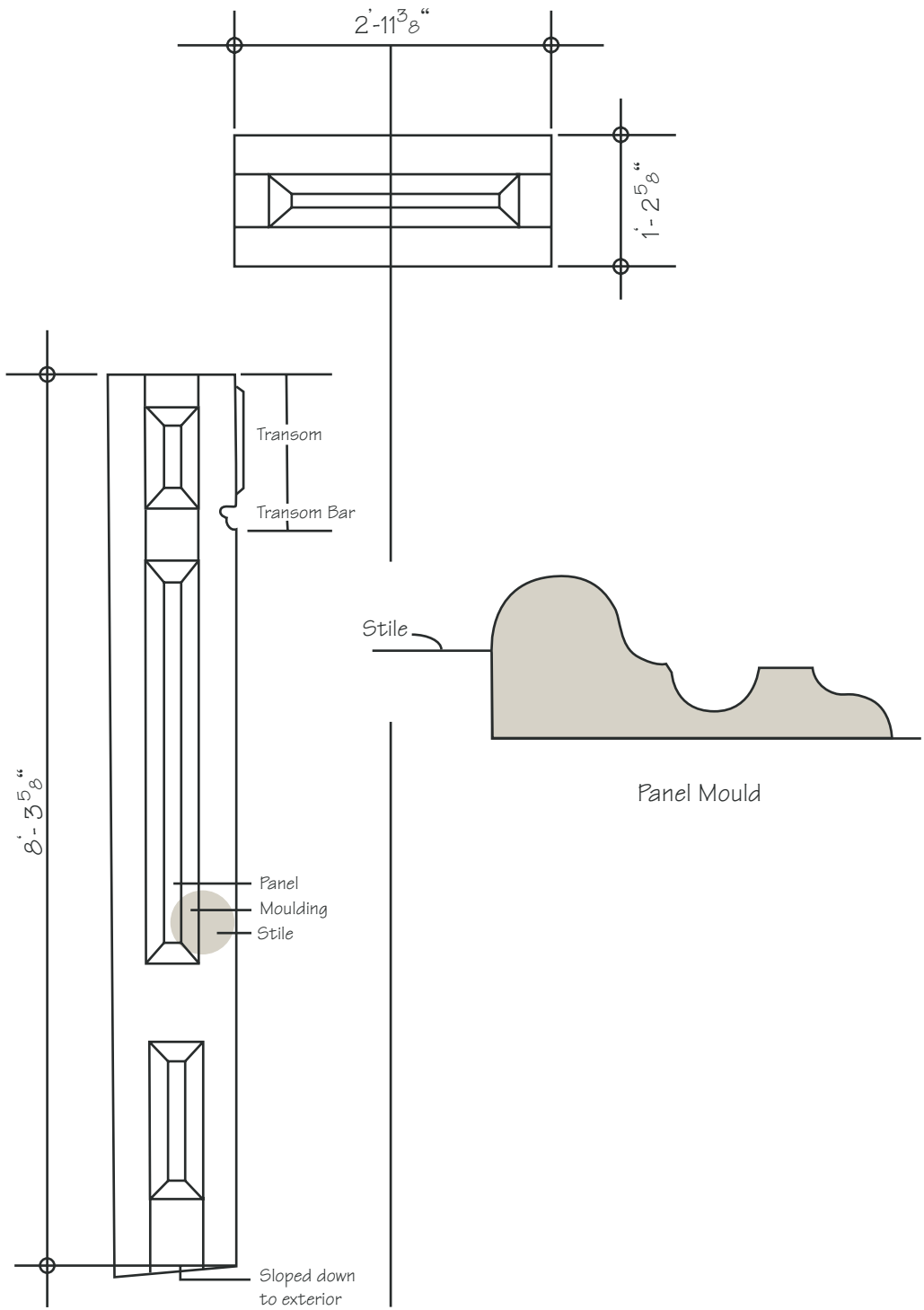

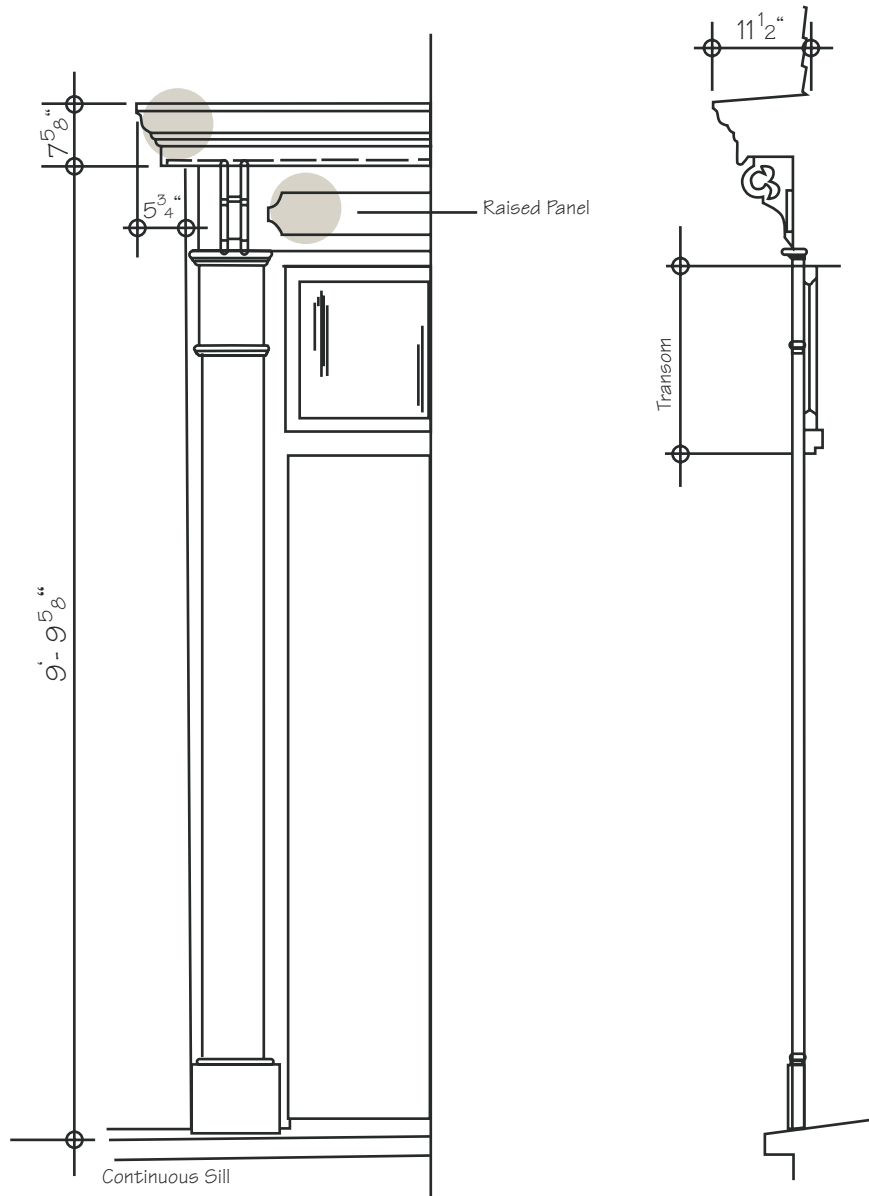

1/2 ELEVATION

PROFILE

DOOR SURROUND

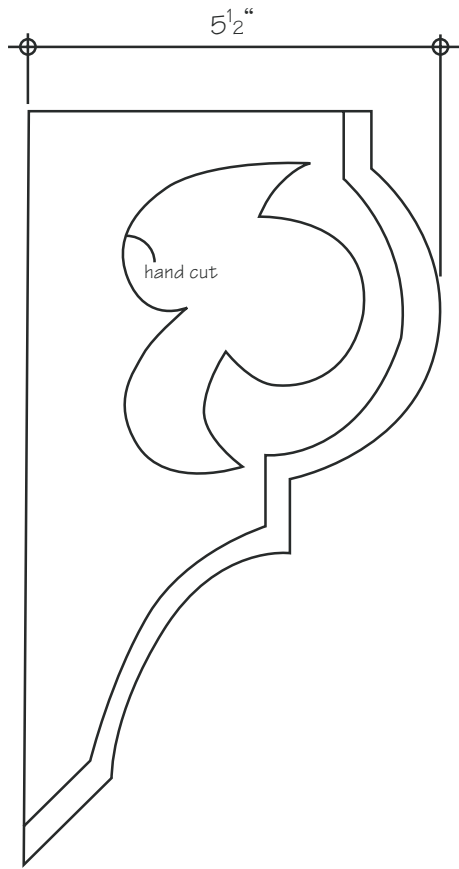

PROFILE

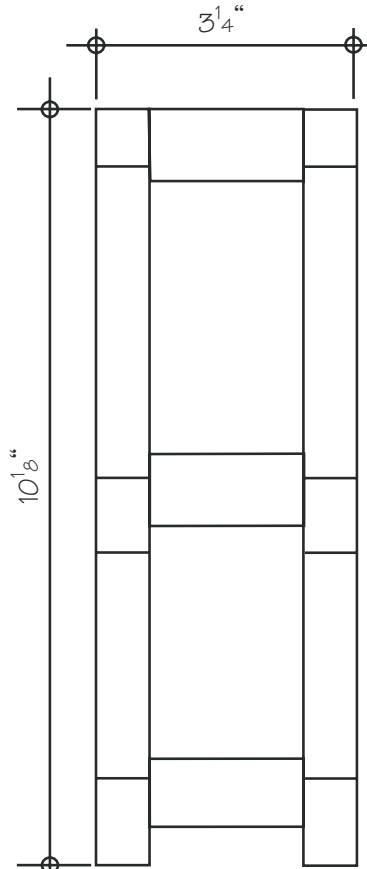

ELEVATION

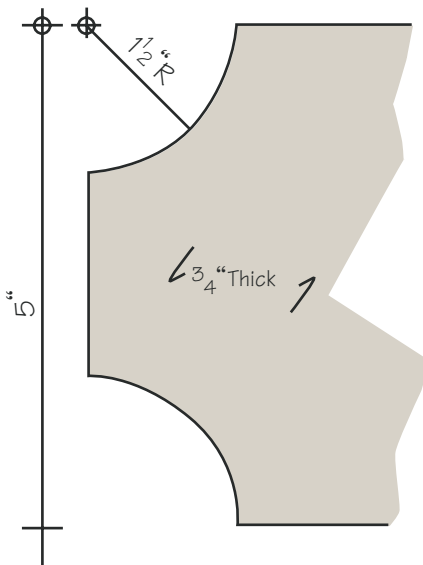

74

Frieze Panel - Part Elevation

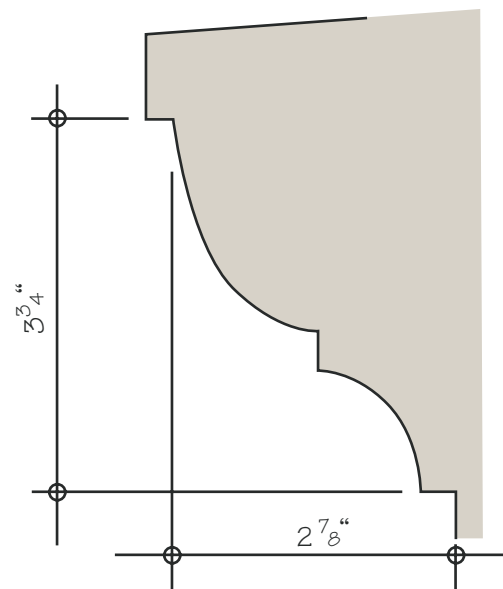

Cornice

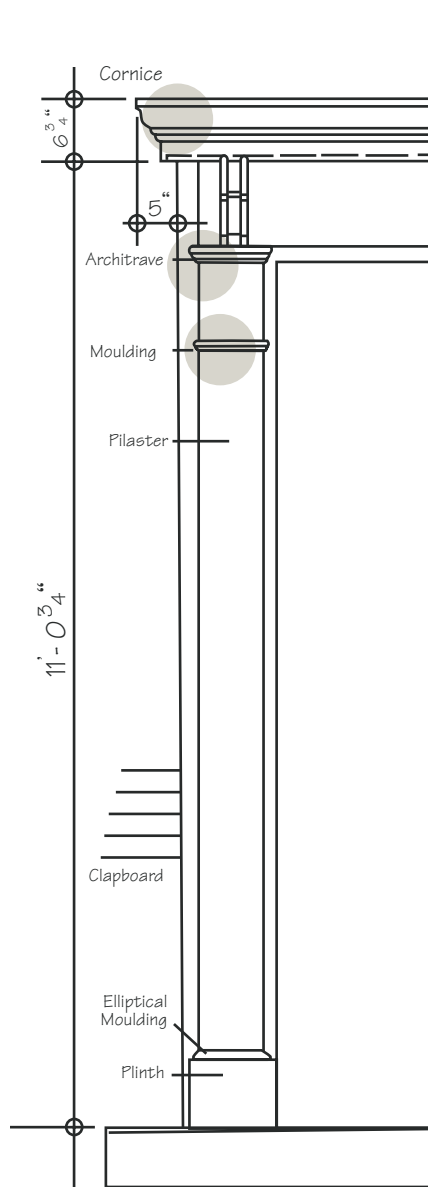

$\frac{1}{2}$ ELEVATION

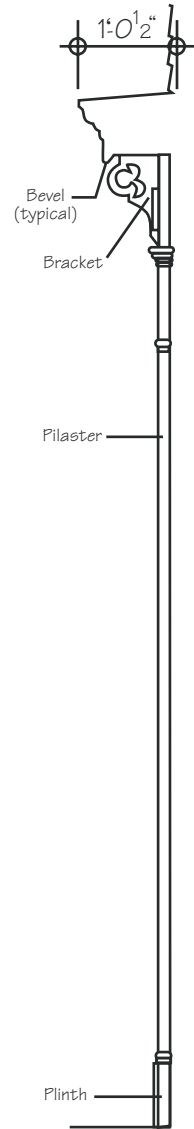

PROFILE

DOOR SURROUND

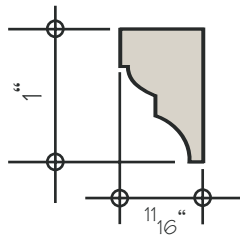

Plaster Moulding

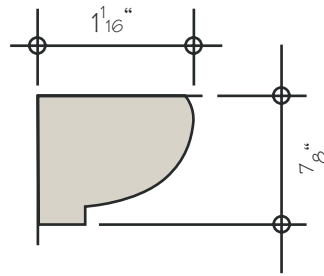

Cove Moulding

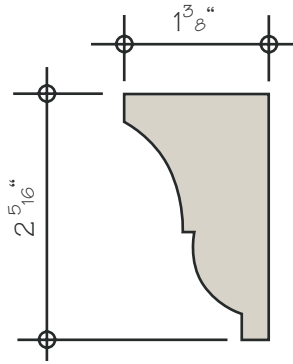

Architrave Moulding

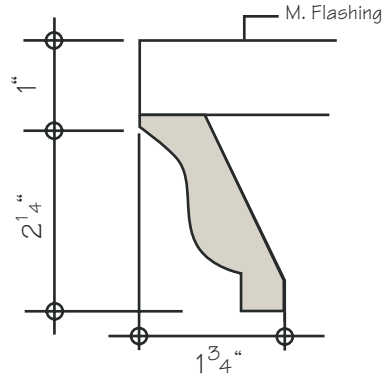

Cornice Moulding

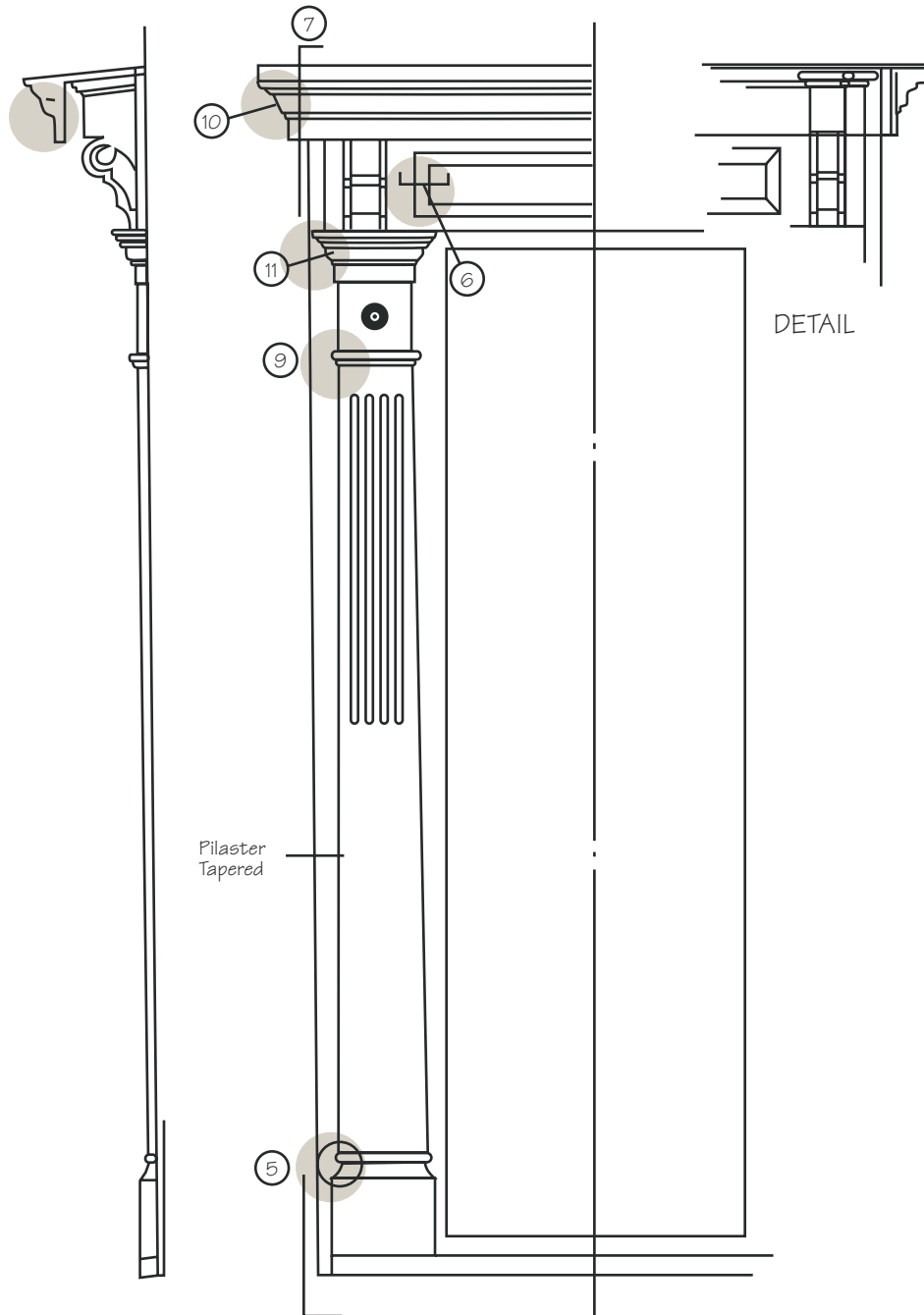

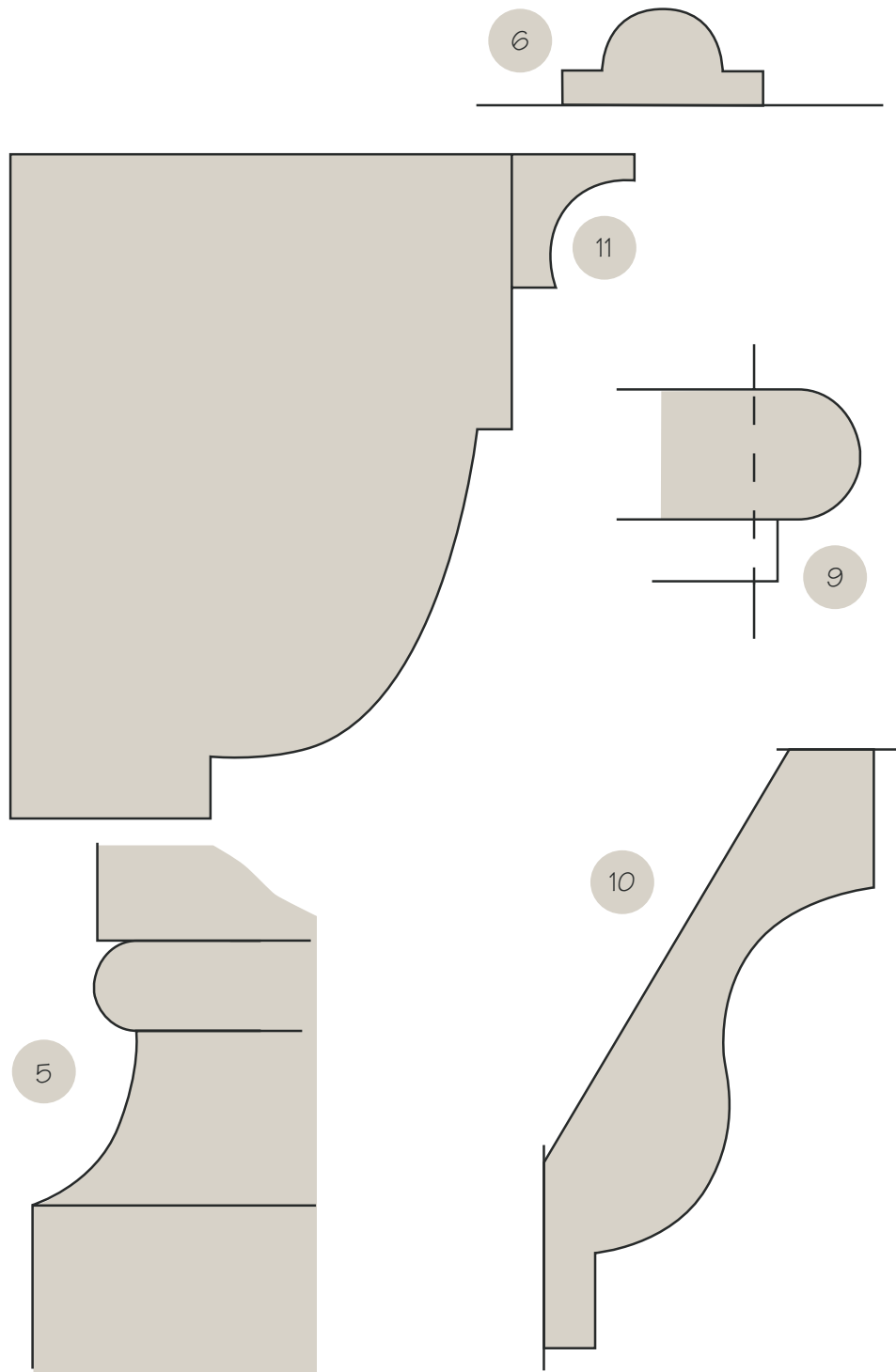

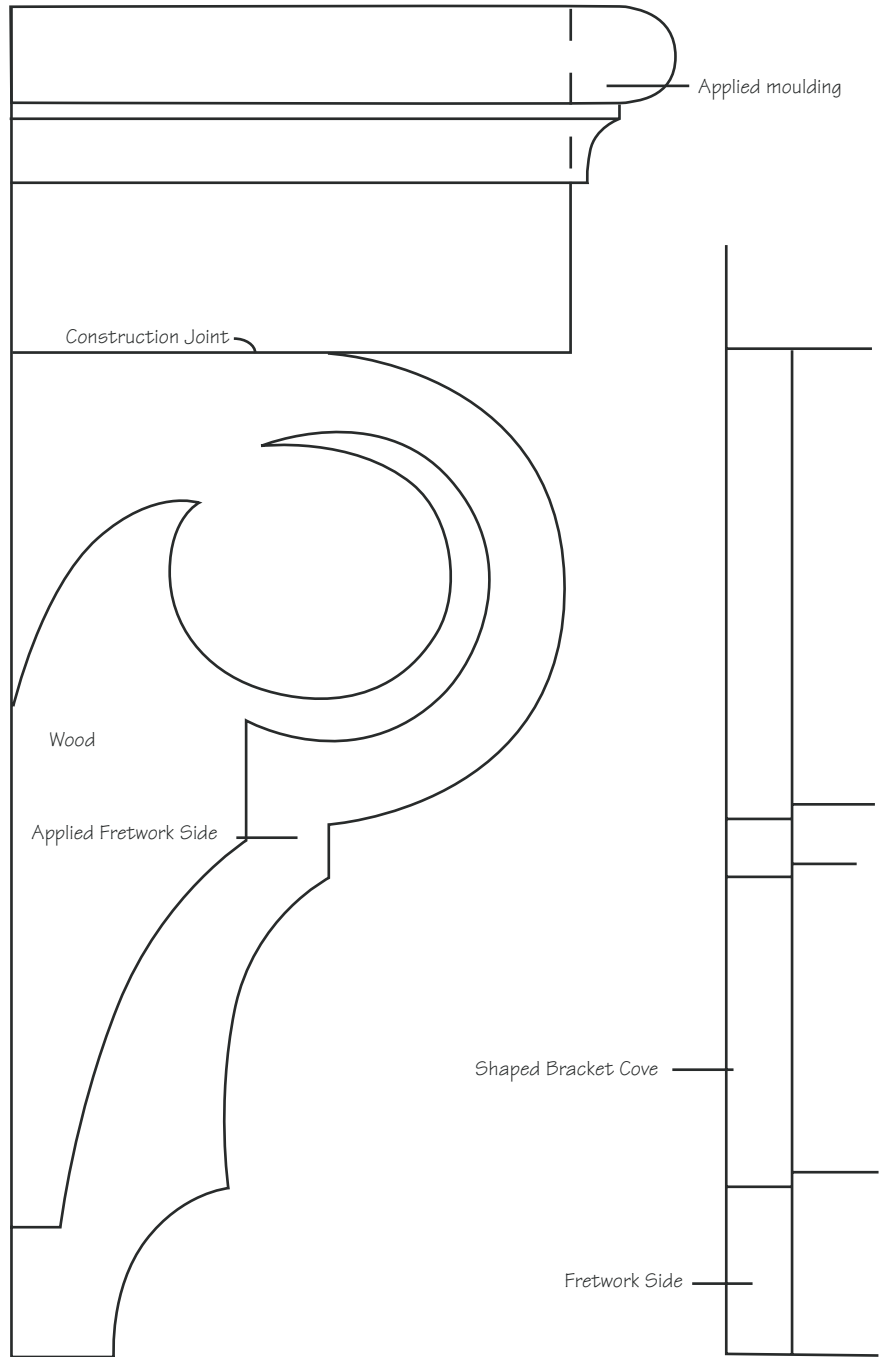

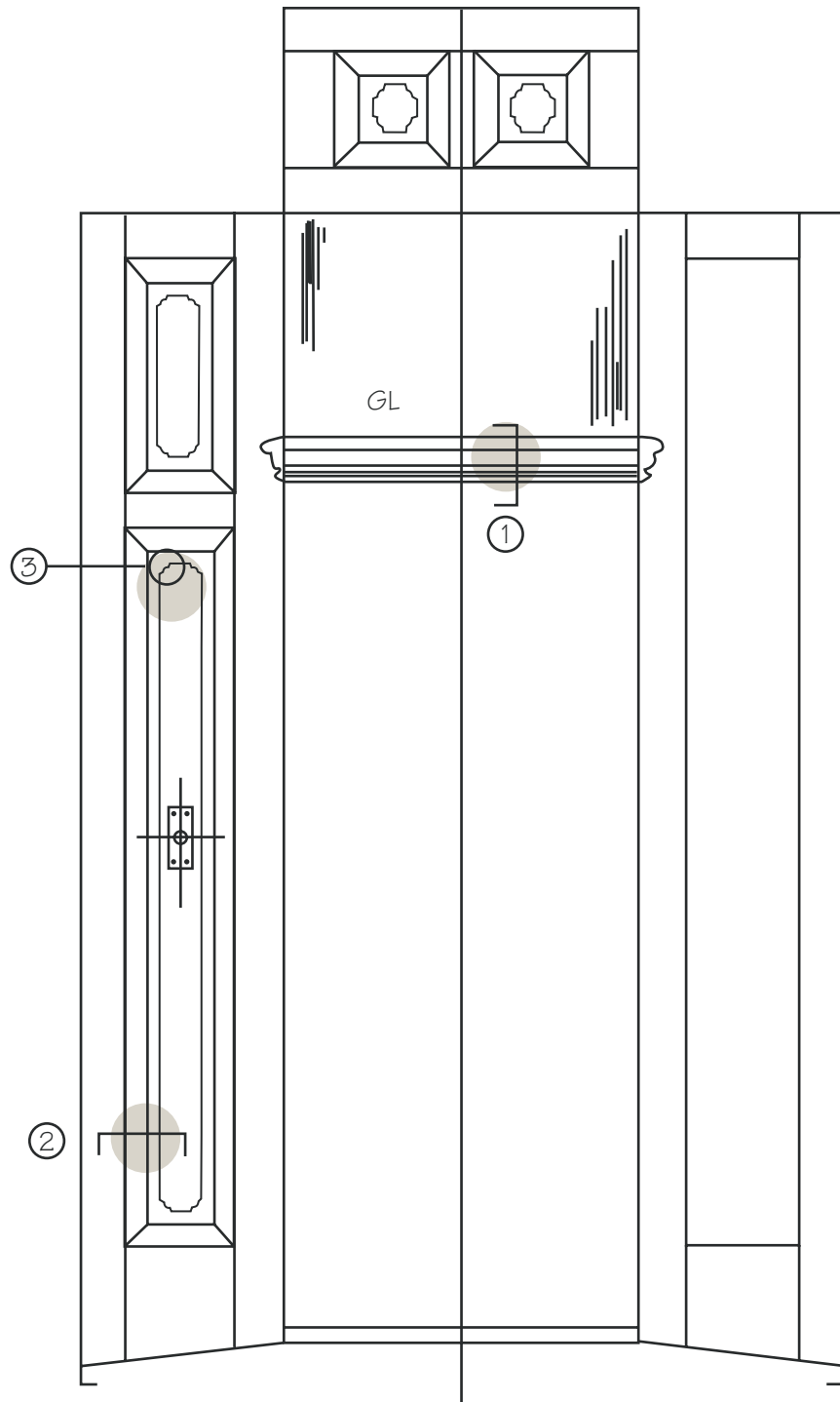

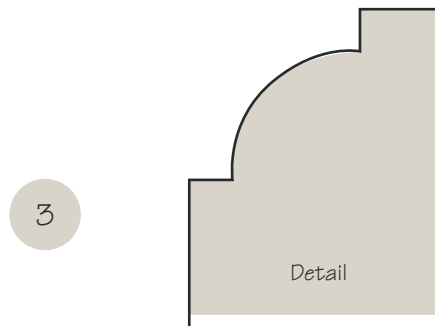
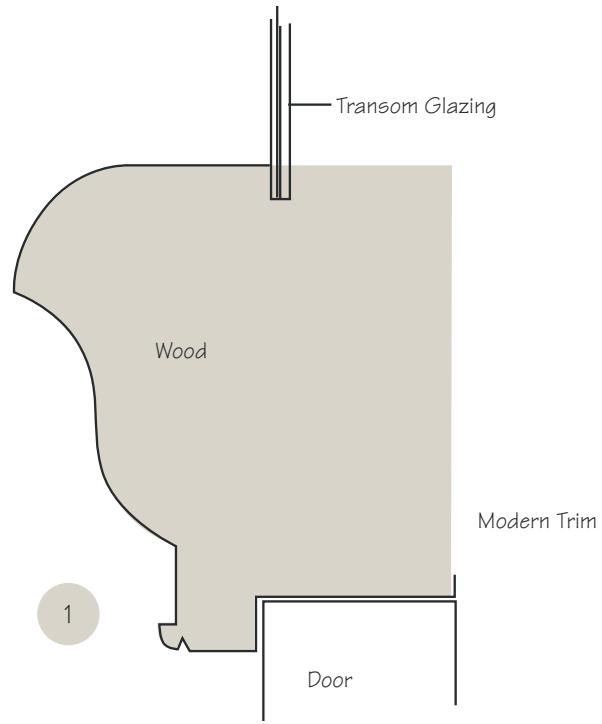

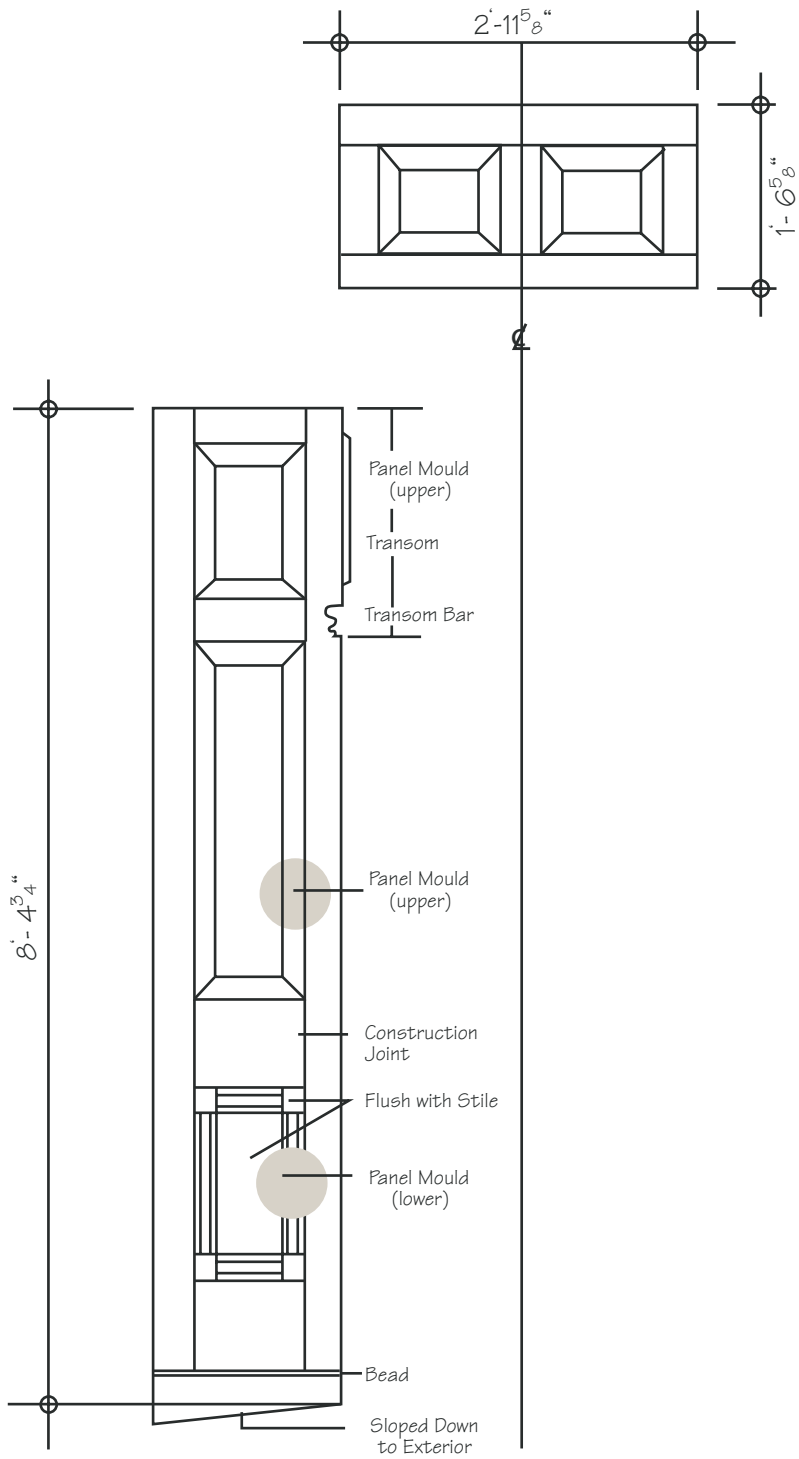



Panel Mould (upper)



Panel Mould (lower)