

Appendix D:

Windows

A walk through the older residential section of downtown St. John's will reveal to the discerning eye the irregularity of the spaces between the windows of the range dwellings. The paramount desire of the builder was to place the windows on the centre line of the major rooms and hallways on the first and second floors and space the dormers evenly on the roof above. This disregard for the more formal approach to fenestration resulted in a lopsided effect from the exterior of the building which adds much character to the typical dwelling built after the great fire of 1892.

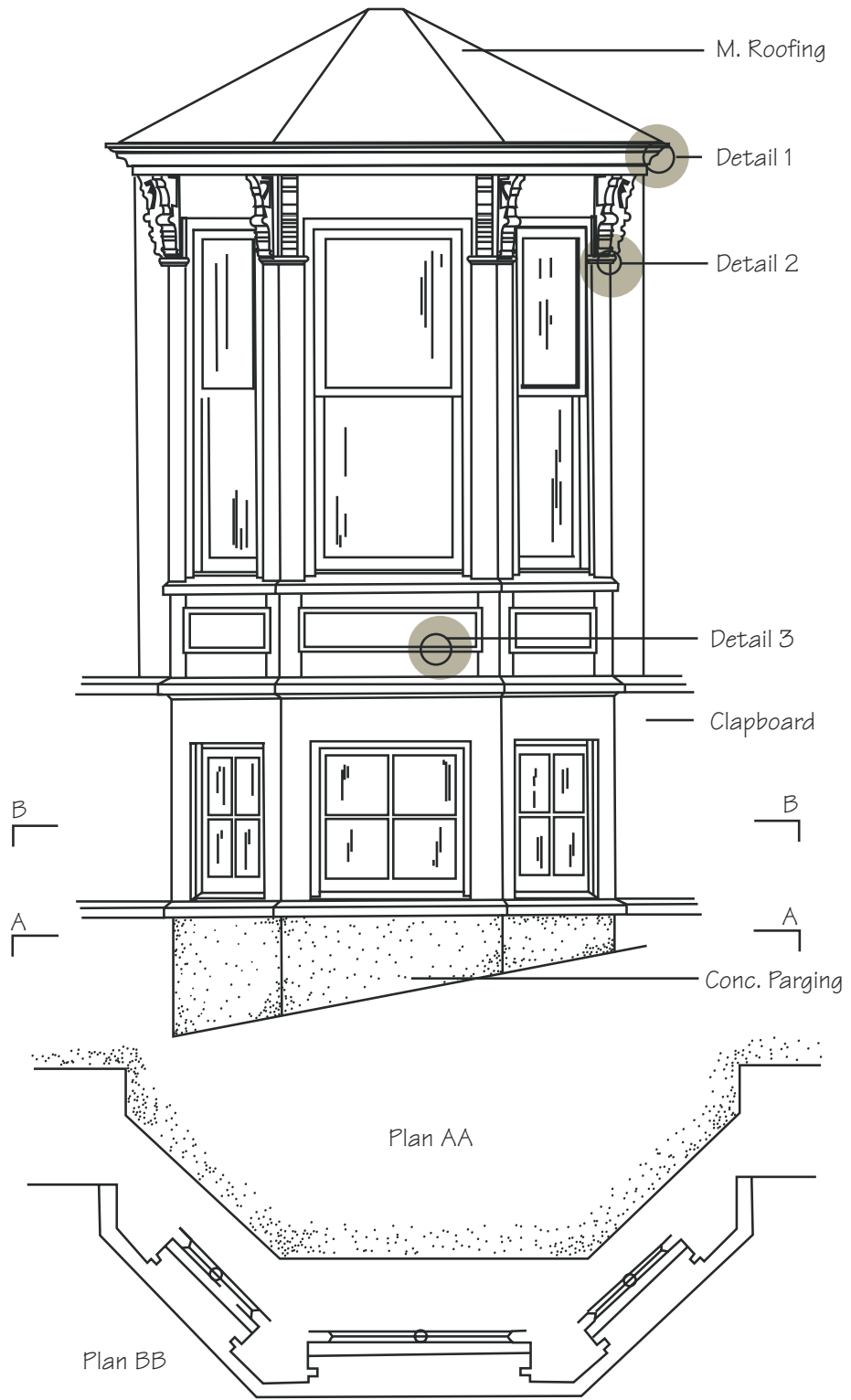

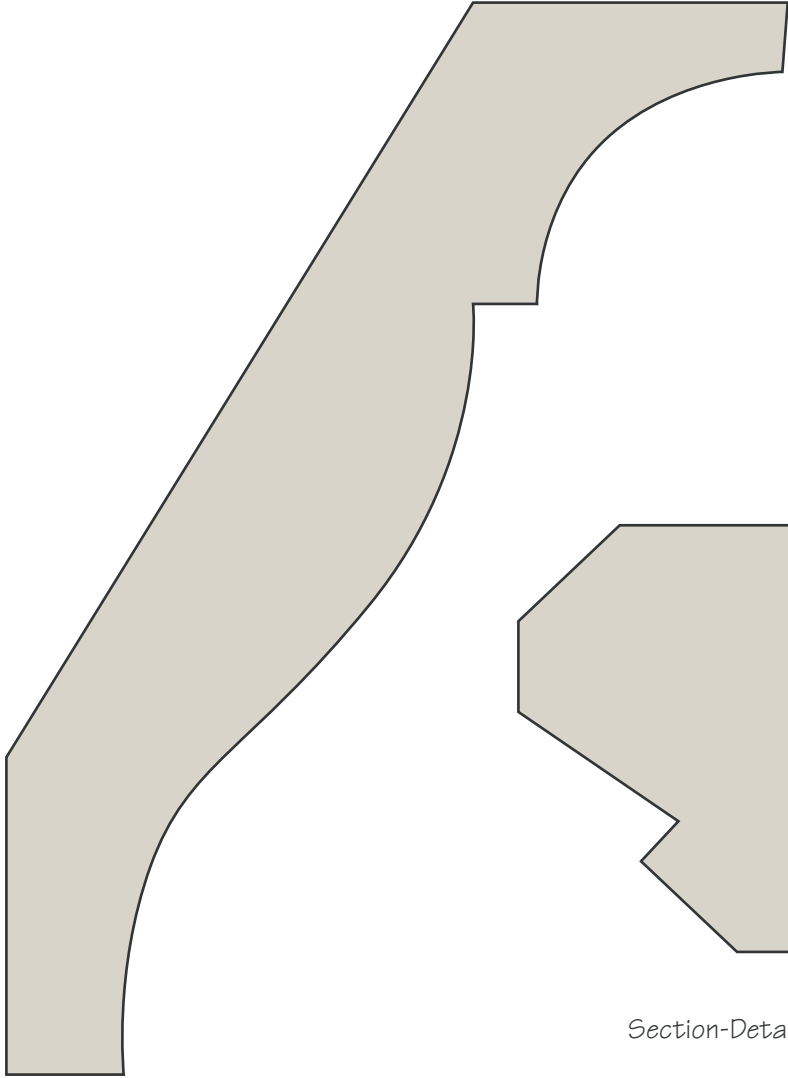

Section-Detail 1

Section-Detail 2

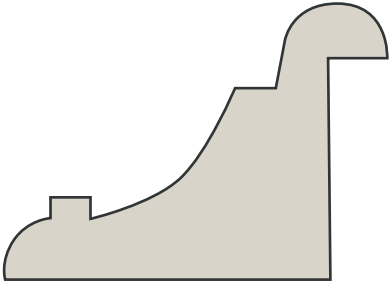

Section-Detail 3

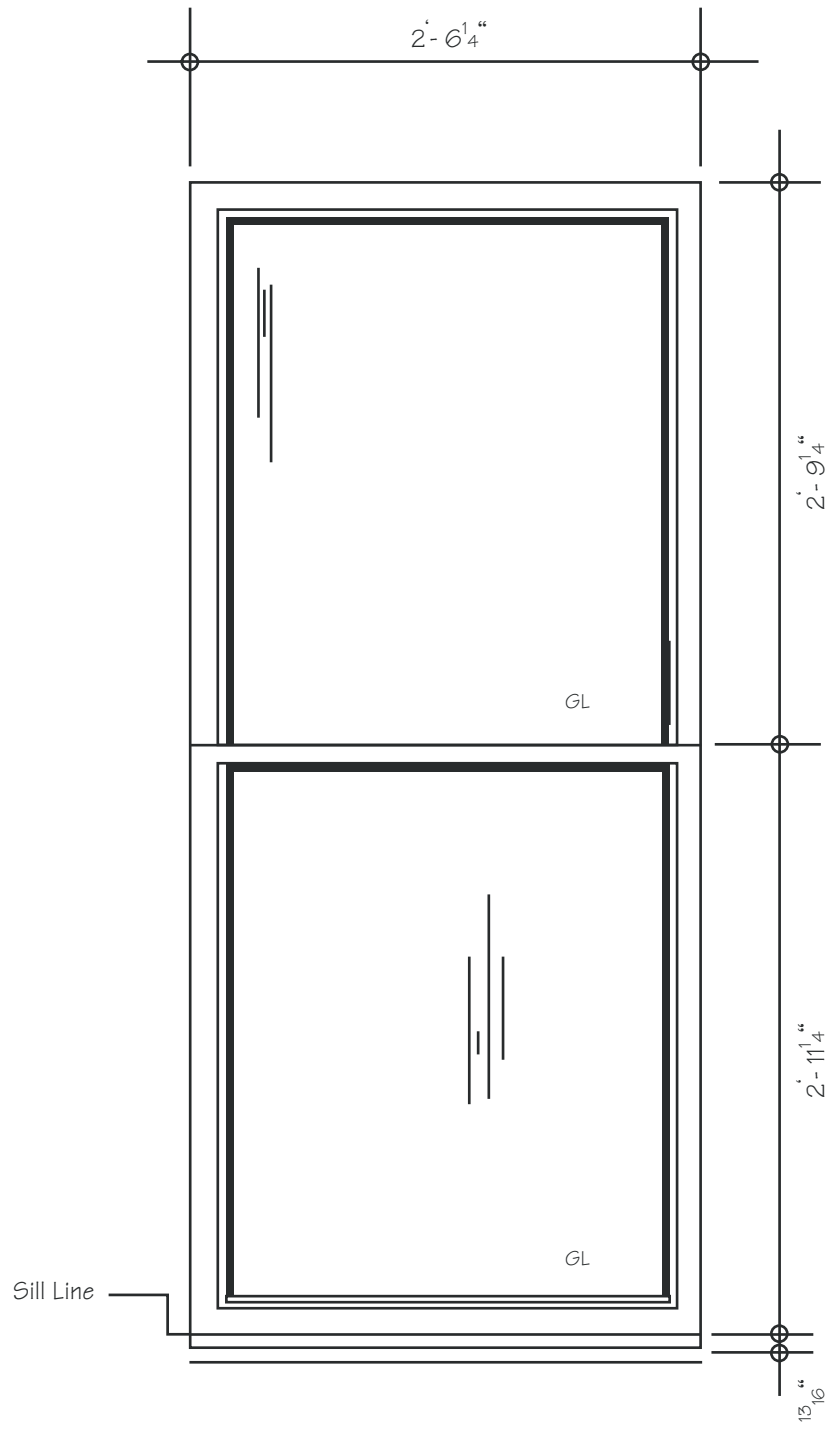

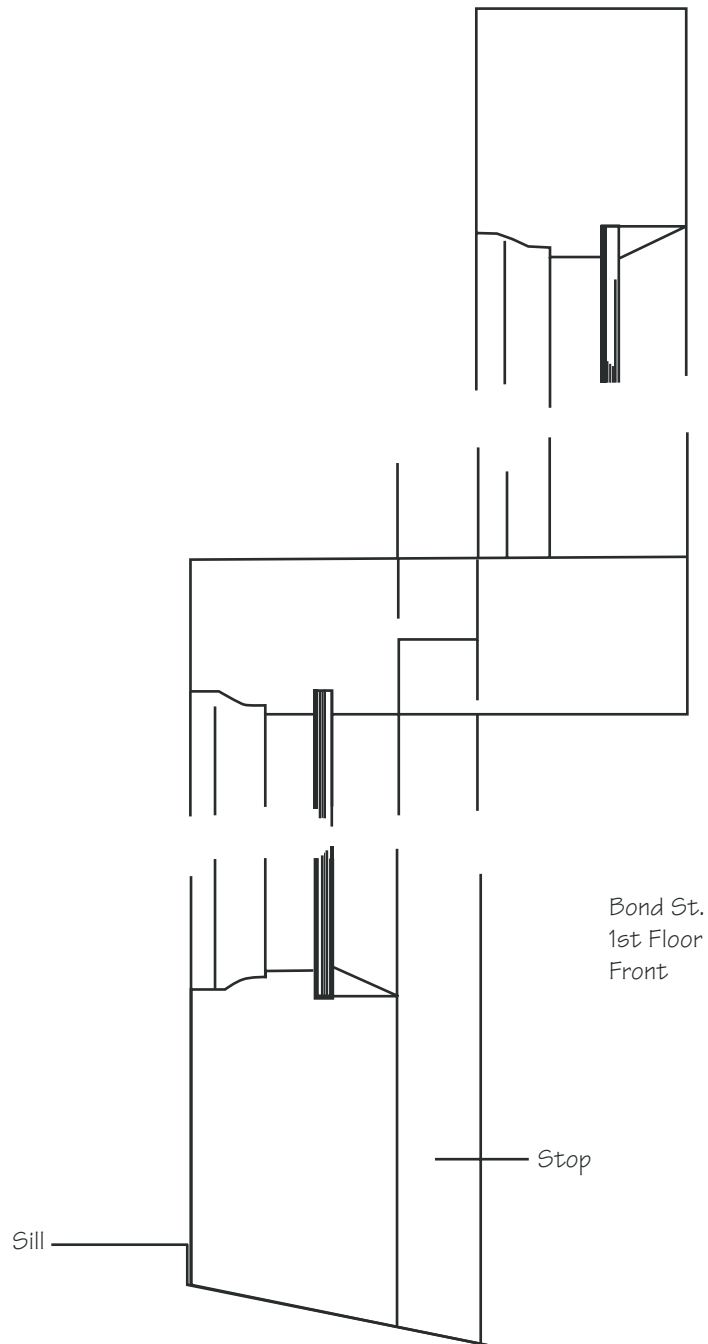

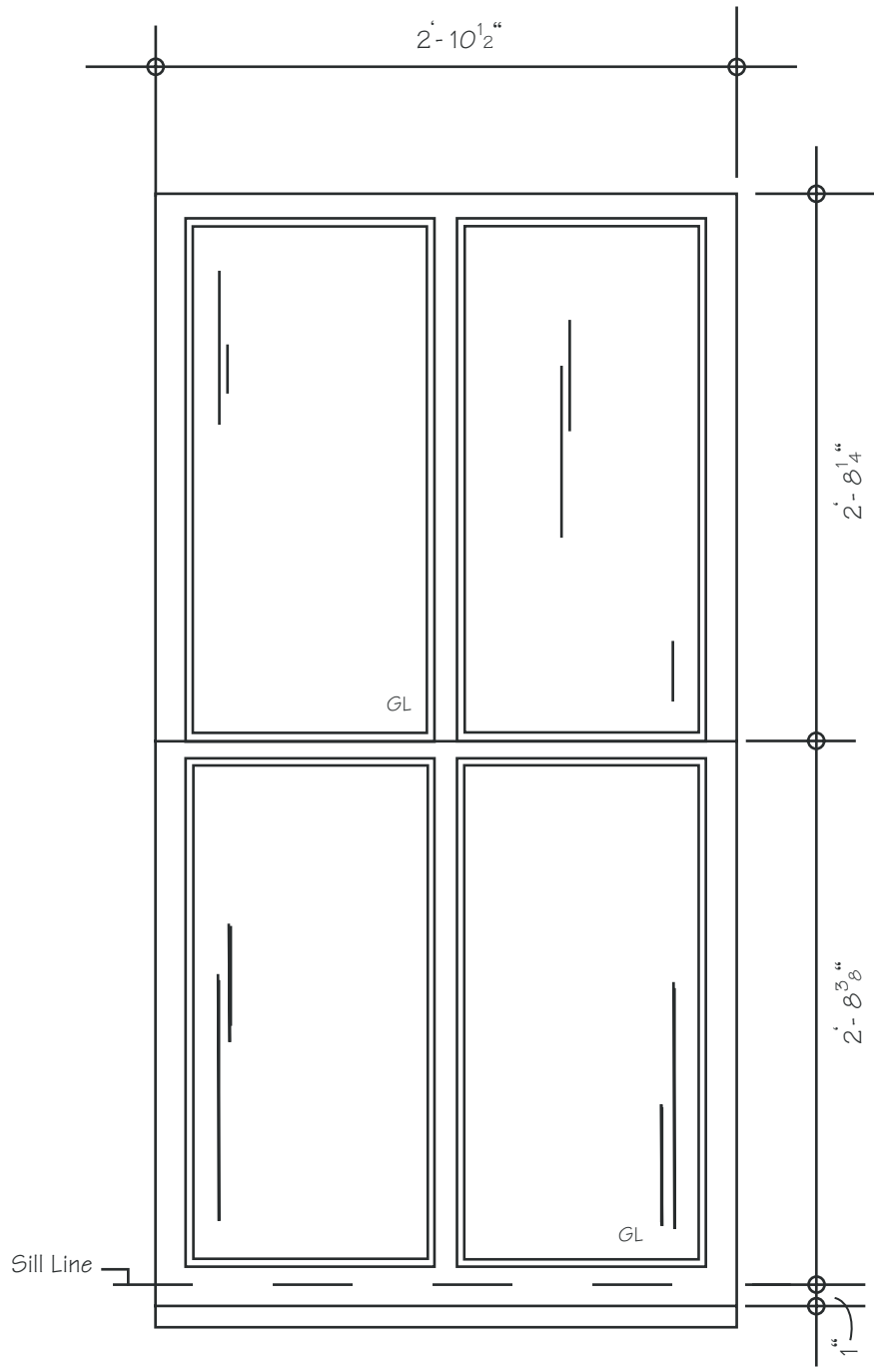

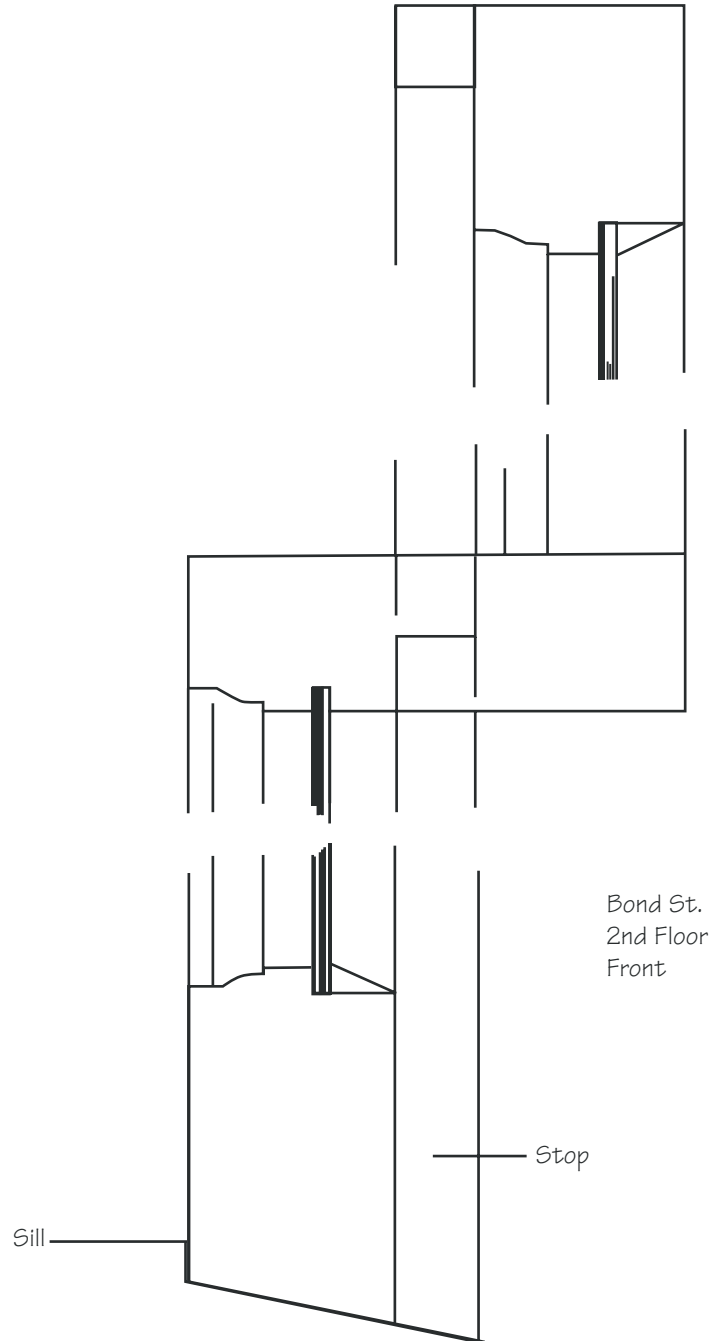

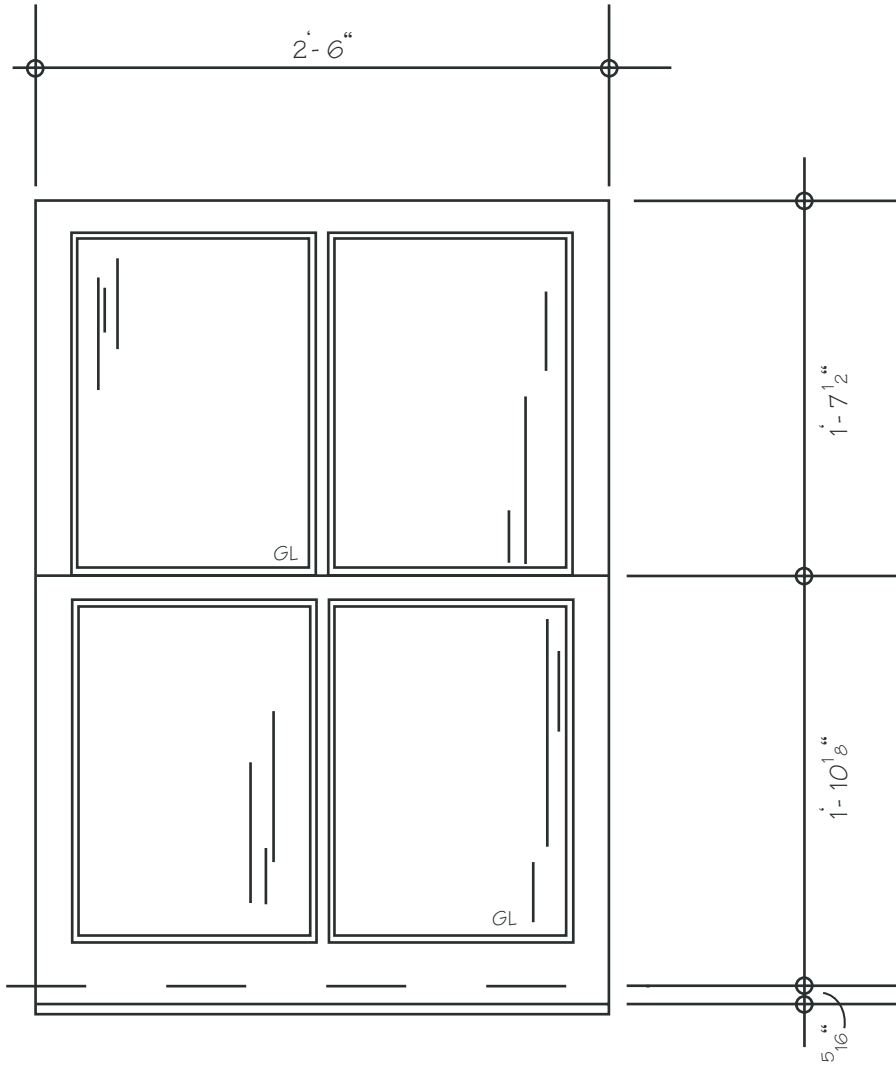

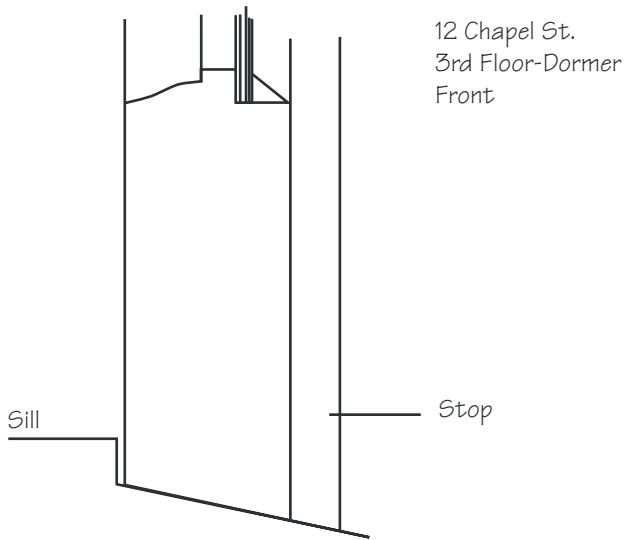
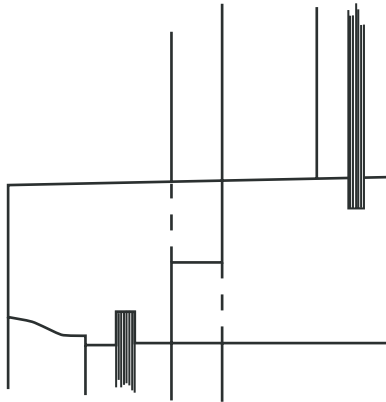
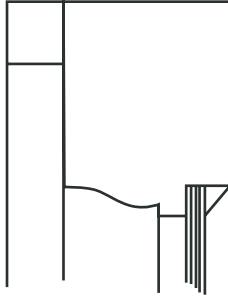

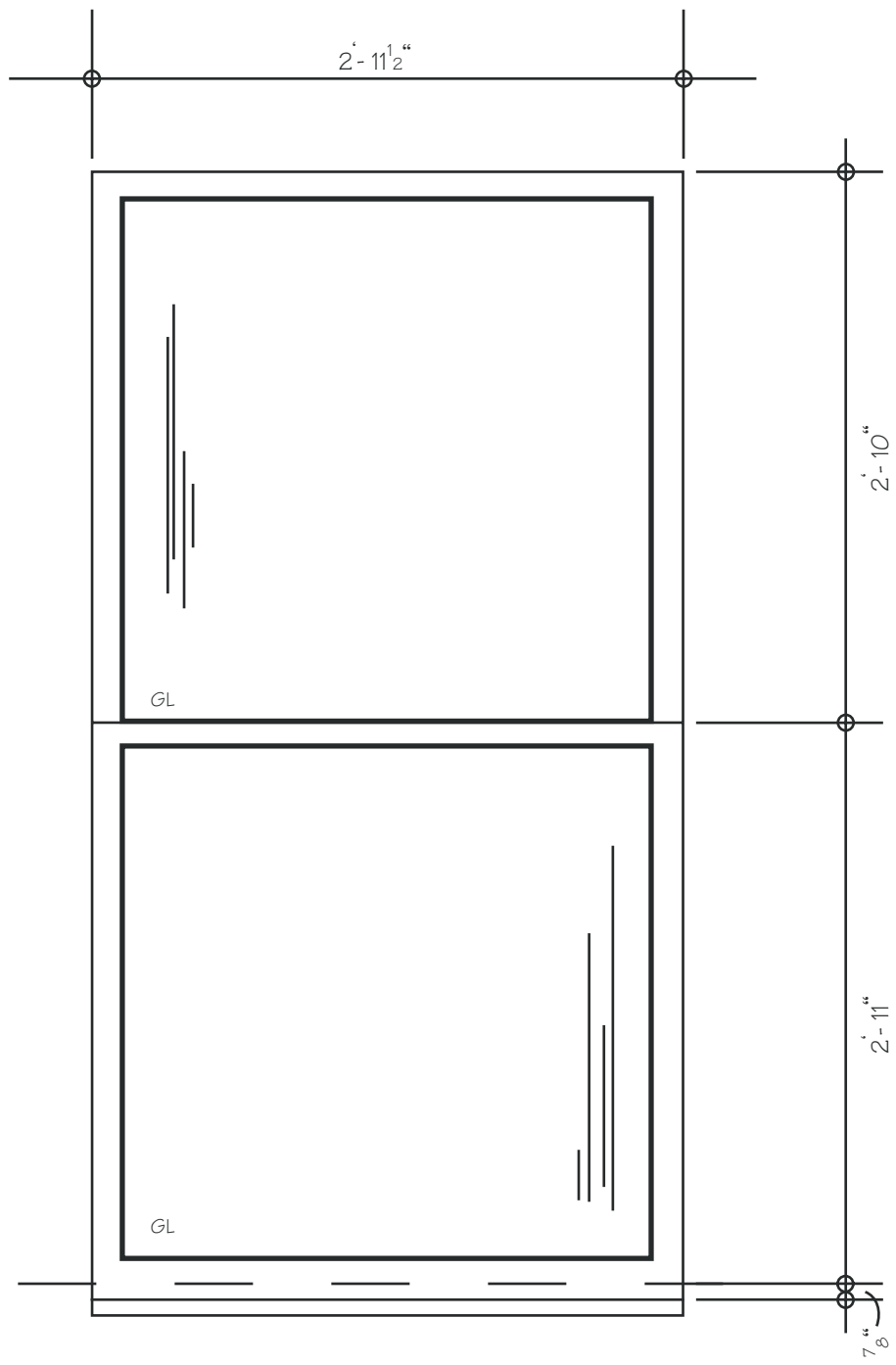

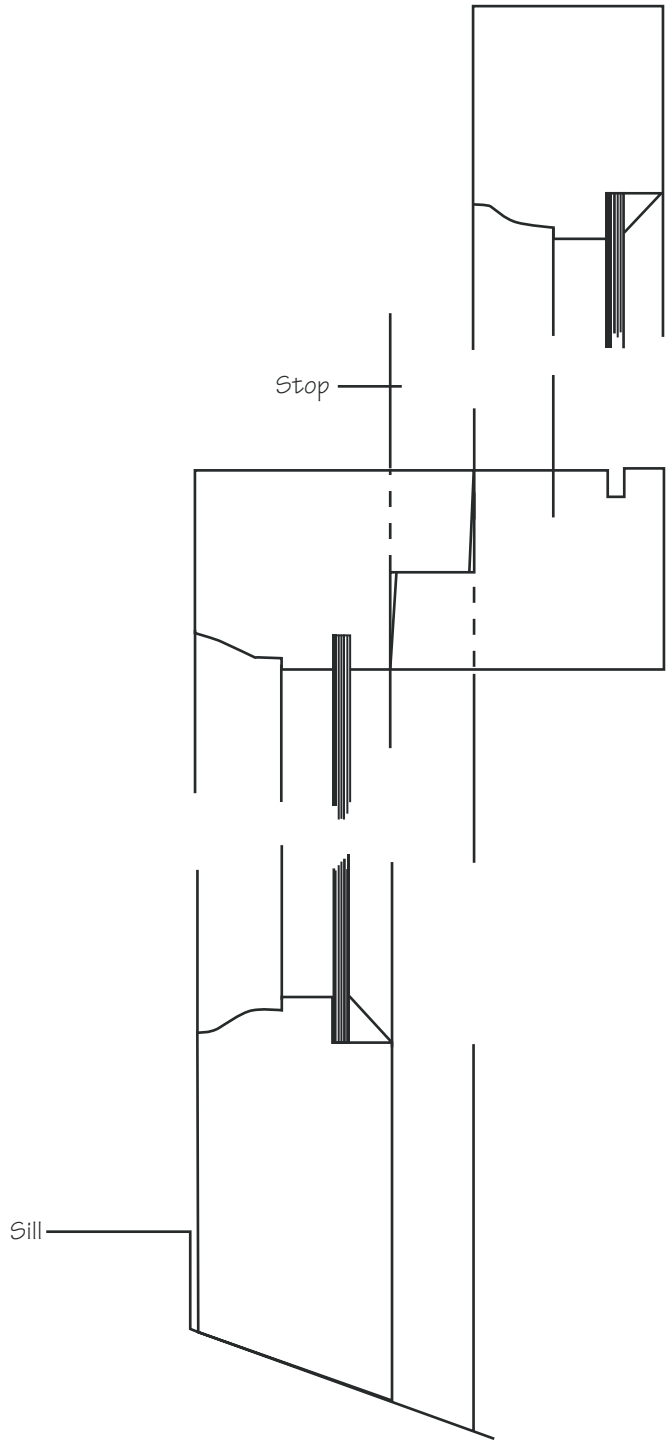

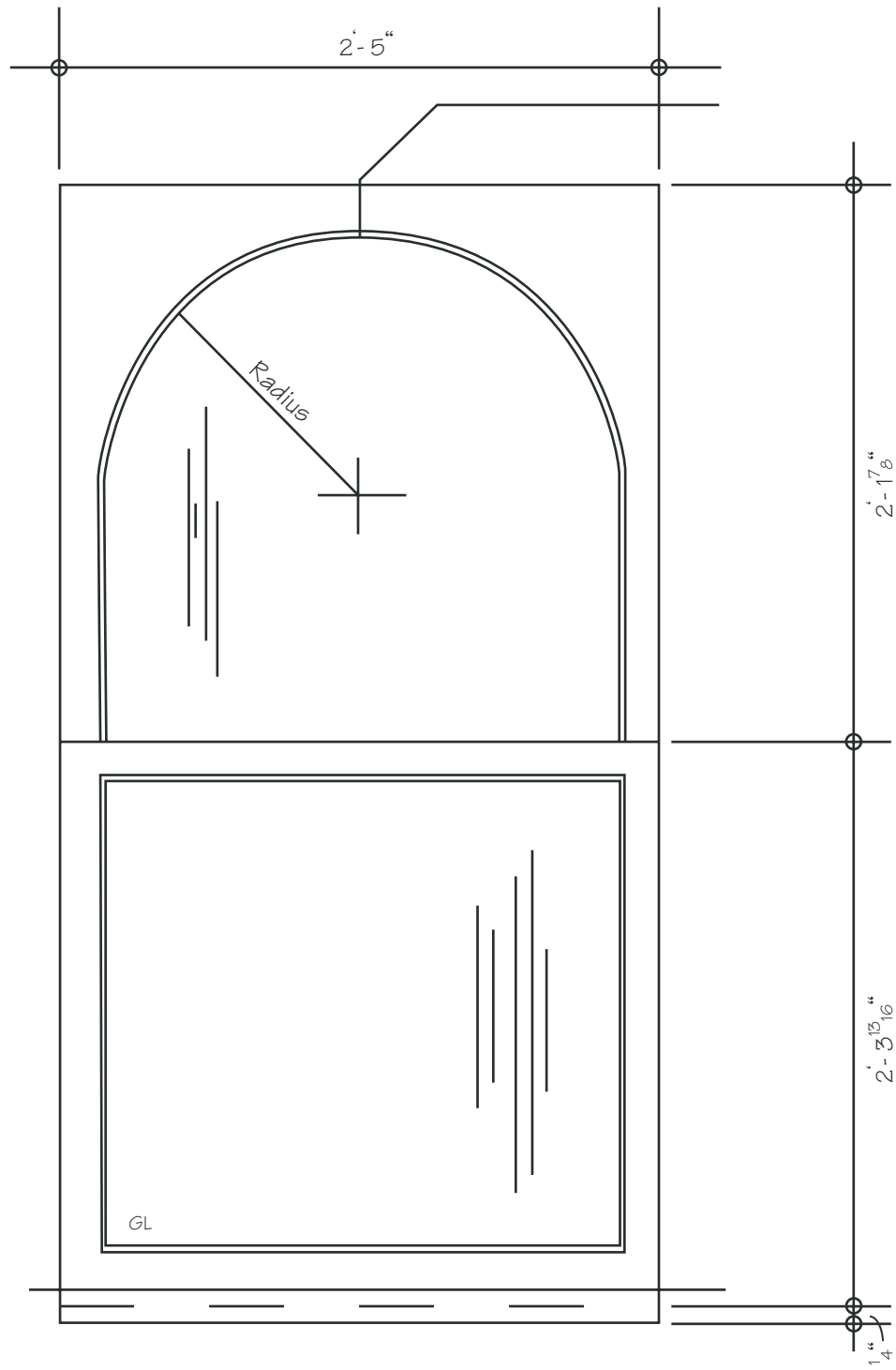

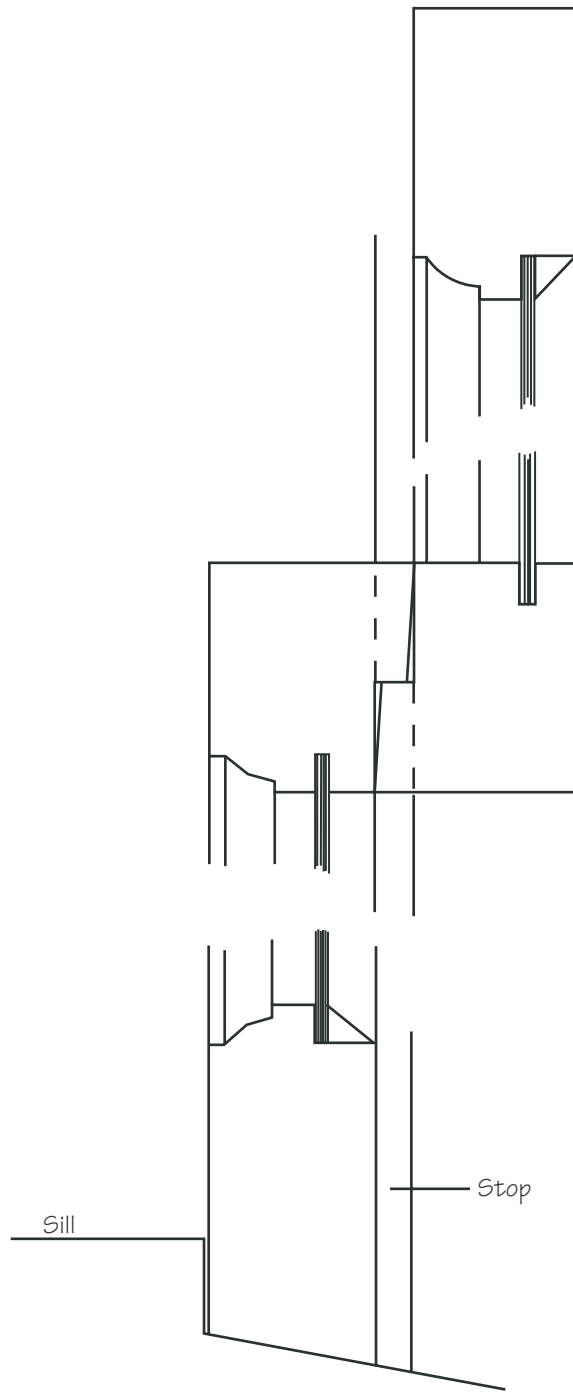

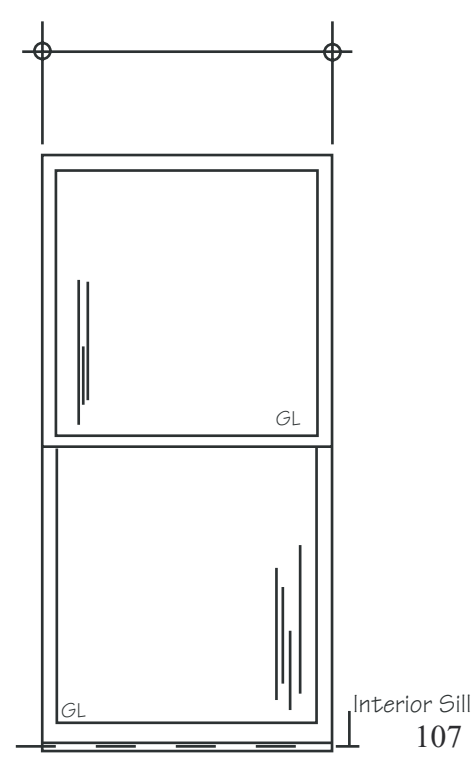
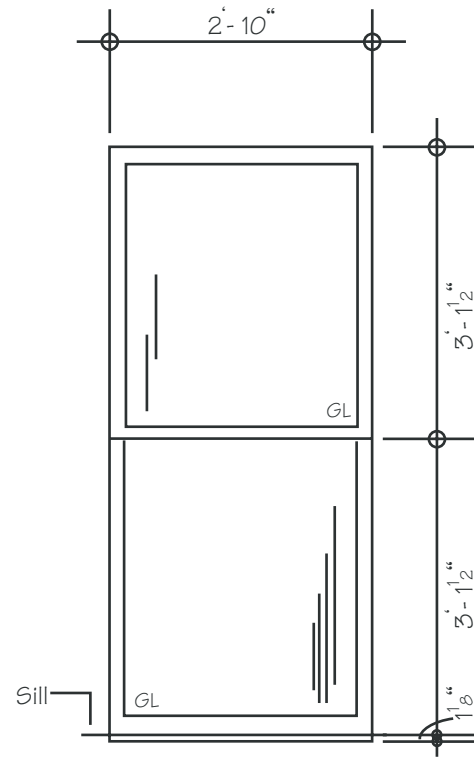
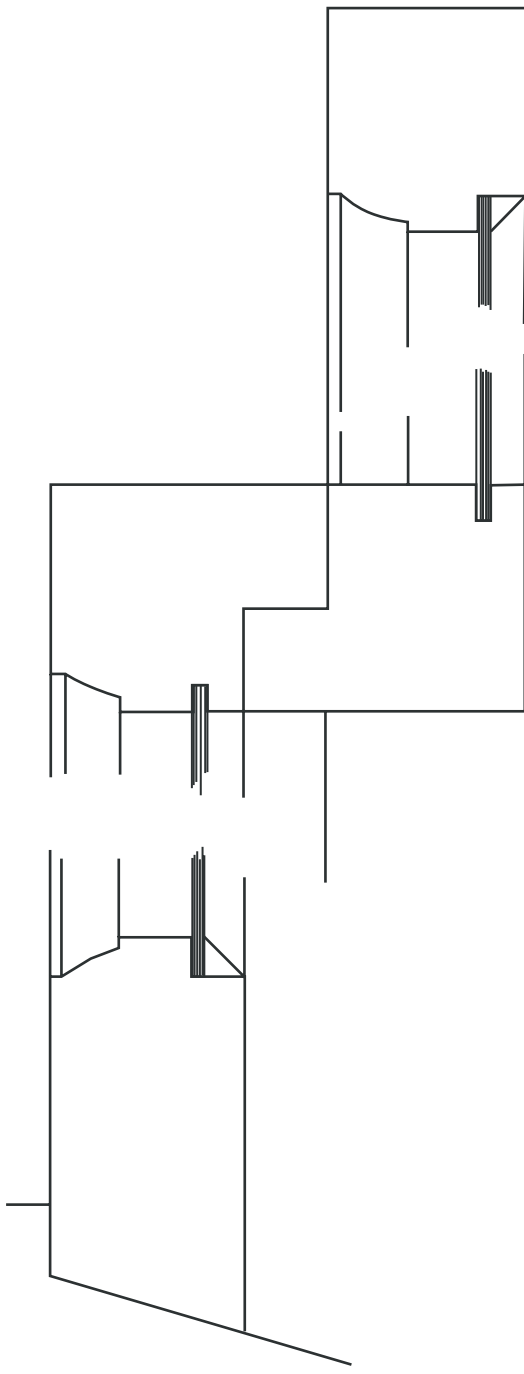

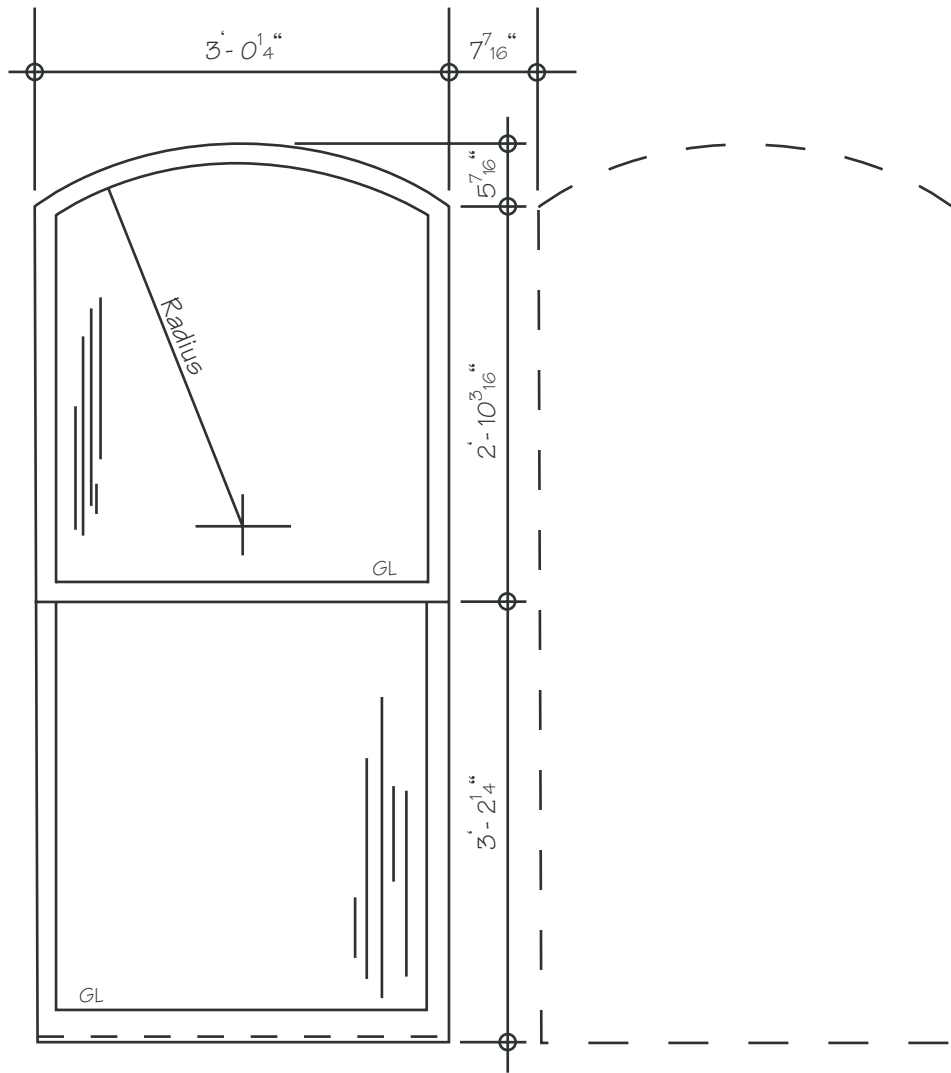

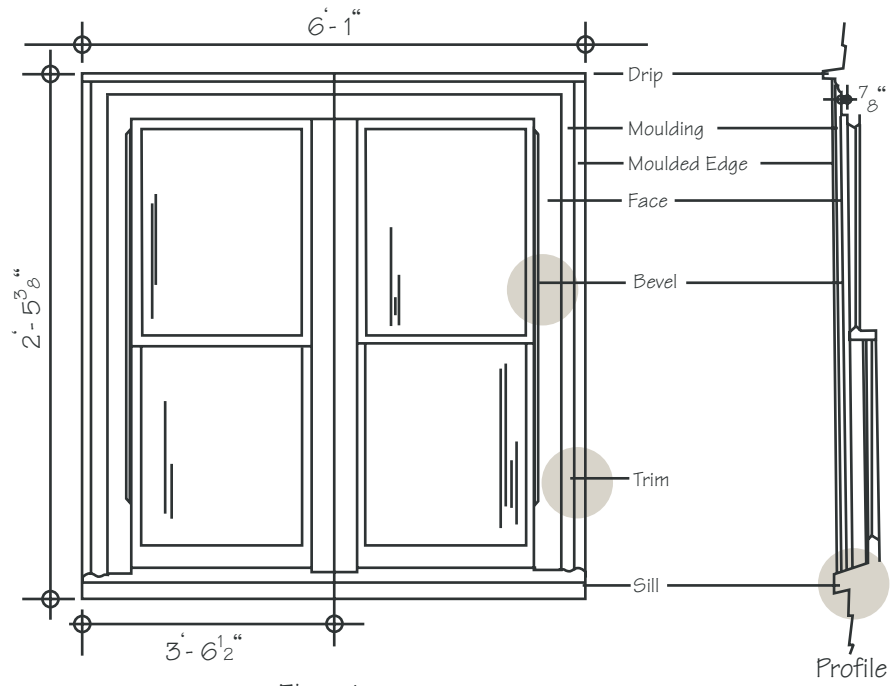

Elevation
Ground Floor Window

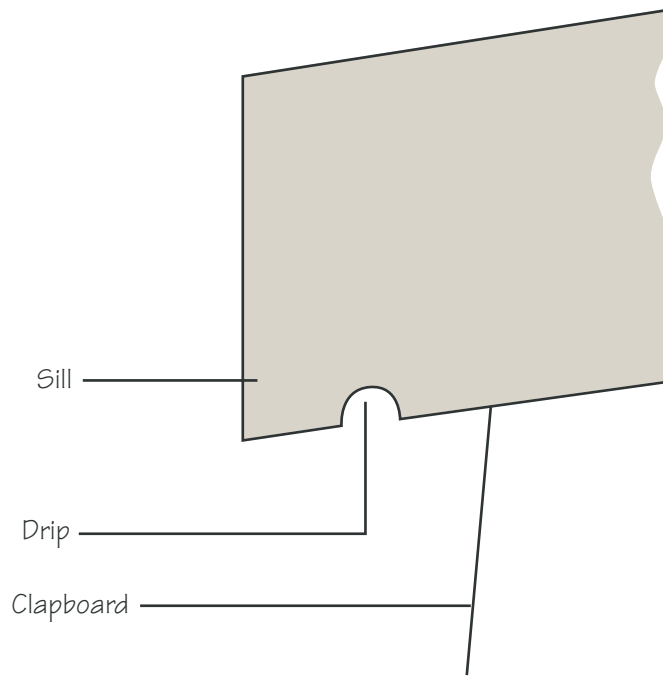

Sill Detail-2nd Floor

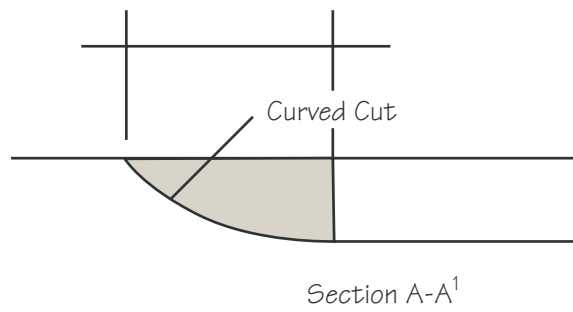
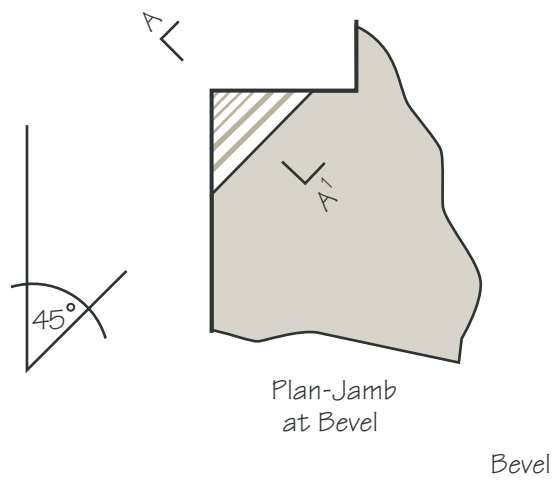
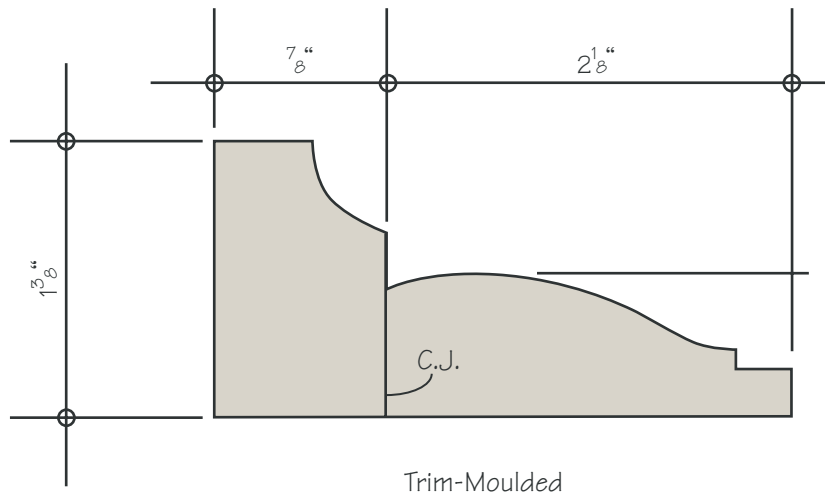

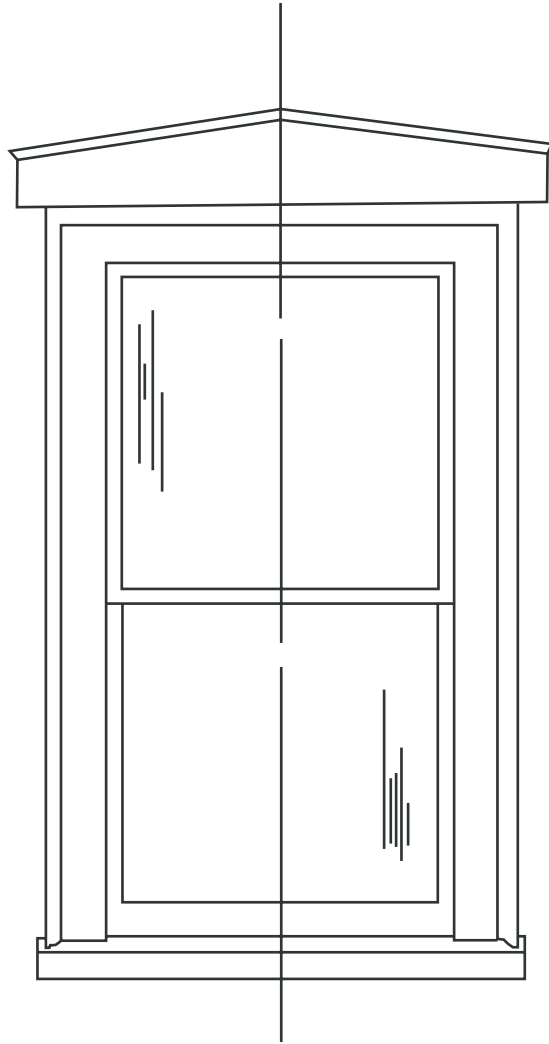

Elevation

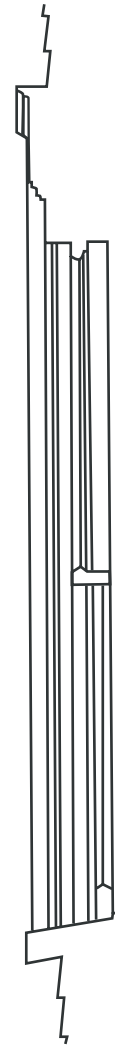

Profile

Ground Floor Window

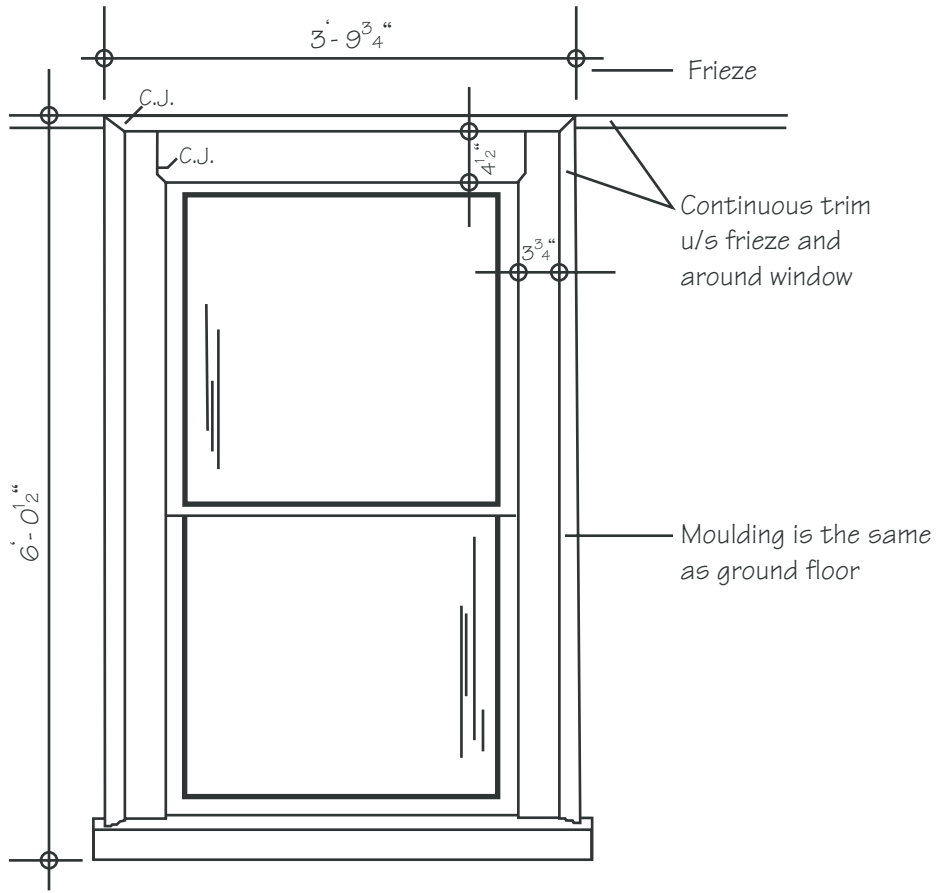

Elevation
 Second Floor Window

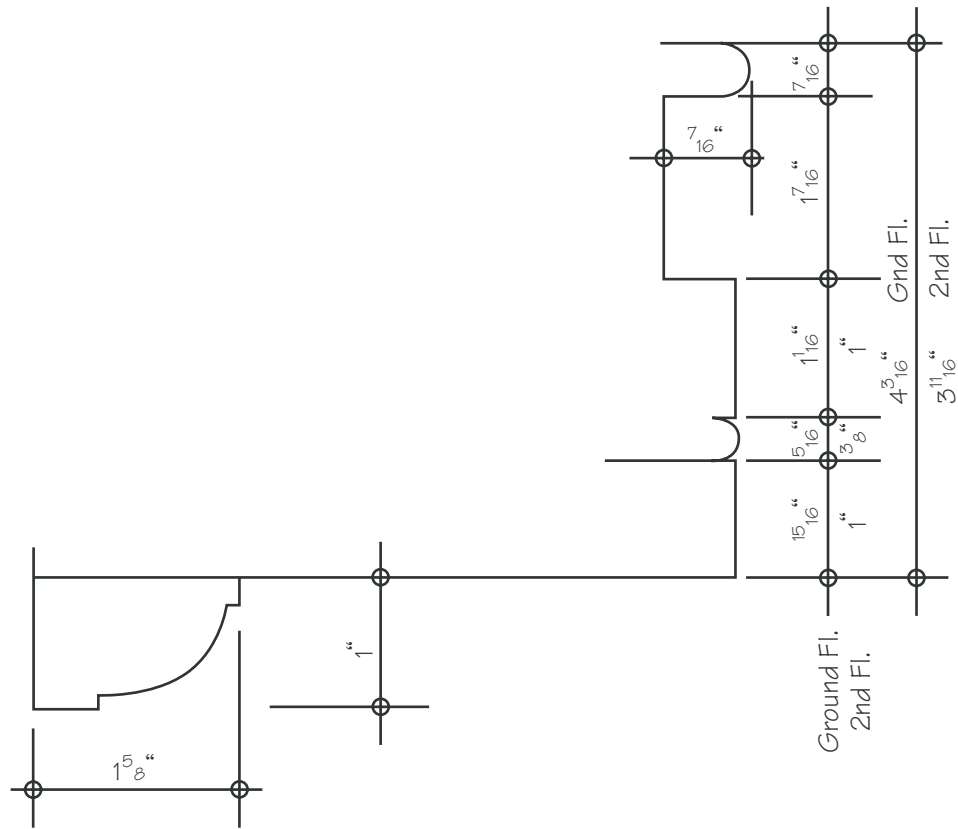

Jamb Profile-Ground Floor

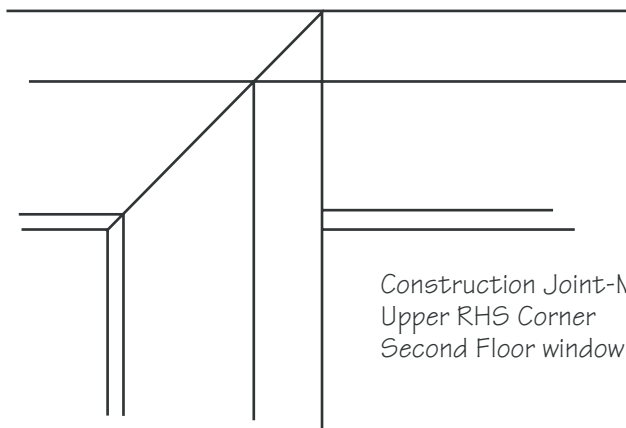

Construction Joint-Moulding
Upper RHS Corner
Second Floor window

